

Volume VIII: Enpure™ High Purity Polypropylene System Manual

Industrial Technical
Manual Series

SECOND EDITION

IPEX ENPURE™ HIGH PURITY
POLYPROPYLENE SYSTEM



IPEX

www.ipexinc.com



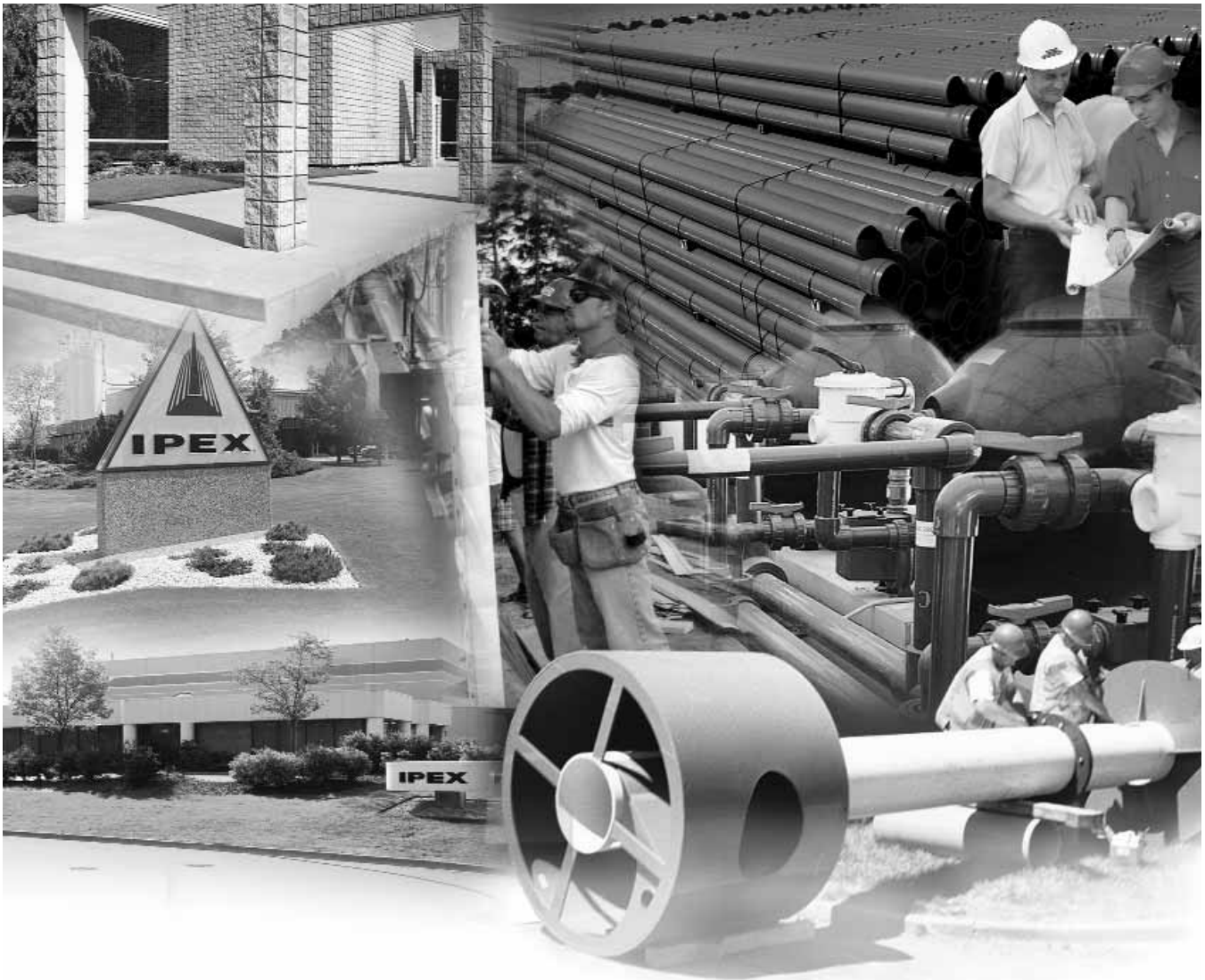
IPEX Enpure™ High Purity Polypropylene System

Industrial Technical Manual Series

Vol. VIII, 2nd Edition

© 2007 by IPEX. All rights reserved. No part of this book may be used or reproduced in any manner whatsoever without prior written permission. For information contact: IPEX, Marketing, 2441 Royal Windsor Drive, Mississauga, Ontario, Canada, L5J 4C7.

The information contained here within is based on current information and product design at the time of publication and is subject to change without notification. IPEX does not guarantee or warranty the accuracy, suitability for particular applications, or results to be obtained therefrom.



ABOUT IPEX

At IPEX, we have been manufacturing non-metallic pipe and fittings since 1951. We formulate our own compounds and maintain strict quality control during production. Our products are made available for customers thanks to a network of regional stocking locations throughout North America. We offer a wide variety of systems including complete lines of piping, fittings, valves and custom-fabricated items.

More importantly, we are committed to meeting our customers' needs. As a leader in the plastic piping industry, IPEX continually develops new products, modernizes manufacturing facilities and acquires innovative process technology. In addition, our staff take pride in their work, making available to customers their extensive thermoplastic knowledge and field experience. IPEX personnel are committed to improving the safety, reliability and performance of thermoplastic materials. We are involved in several standards committees and are members of and/or comply with the organizations listed on this page.

For specific details about any IPEX product, contact our customer service department.



SAFETY ALERTS

Engineered thermoplastics are safe inert materials that do not pose any significant safety or environmental hazards during handling or installation. However, improper installation or use can result in personal injury and/or property damage. It is important to be aware of and recognize safety alert messages as they appear in this manual.

The types of safety alert messages are described below.



This safety alert symbol indicates important safety messages in this manual. When you see this symbol be alert to the possibility of personal injury and carefully read and fully understand the message that follows.



WARNING

“WARNING” identifies hazards or unsafe practices that can result in severe personal injury or death if instructions, including recommended precautions, are not followed.



CAUTION

“CAUTION” identifies hazards or unsafe practices that can result in minor personal injury or product or property damage if instructions, including recommended precautions, are not followed.

Note: The use of the word “NOTE” signifies special instructions which are important but are not related to hazards.

For the materials described in this manual, the following warning applies.



WARNING

AIR/GAS



- NEVER use compressed air or gas in PVC/CPVC/PP/PVDF pipe and fittings.
- NEVER test PVC/CPVC/PP/PVDF pipe and fittings with compressed air or gas, or air-over-water boosters.
- ONLY use PVC/CPVC/PP/PVDF pipe for water and approved chemicals.

Use of compressed air or gas in PVC/CPVC/PP/PVDF pipe and fittings can result in explosive failures and cause severe injury or death.

This page intentionally
left blank

CONTENTS

Enpure™ High Purity Polypropylene System Manual

	About IPEX	
	Safety Alerts	<i>ii</i>
Section One:	General Information	
	Overview	1
	Benefits	2
	High Purity Systems	3
	Material Description	7
	Applications	8
Section Two:	Process Piping Design	
	Introduction	9
	Design Process	10
	Design Considerations	14
Section Three:	Installation	
	Introduction	17
	Handling and Storage	17
	Joining Methods – Socket Fusion	18
	Joining Methods – Threading	30
	Joining Methods – Flanging	33
	Installation	35
	Installation Considerations	39
	Testing	40
	Repair	40
Section Four:	Valves	
	VKD Series Ball Valves	41
	VM Series Diaphragm Valves	43
	SR Series Ball Check Valves	45
	Recirculating Faucet	47
Section Five:	Dimensions	
	Pipe	49
	Fittings	50
	Valves	54
	Accessories	55
Section Six:	Specifications	
	Enpure PP High Purity Industrial Piping Systems	57

TABLE AND FIGURES

Table

Table 1	Static Leach Test Results	4
Table 2	Static Leach Test Results	4
Table 3	Physical Properties	6
Table 4	Pressure Ratings for Enpure Sch. 40 & Sch. 80 PP pipe (psi)	10
Table 5	Carrying Capacity and Friction Loss for Schedule 40 Thermoplastic Pipe	11
Table 6	Carrying Capacity and Friction Loss for Schedule 80 Thermoplastic Pipe	12
Table 7	Friction Loss through Fittings (in feet)	13
Table 8	Coefficients of Thermal Expansion	14
Table 9	PP Linear Expansion (ΔL) in inches	14
Table 10	Coefficients of Thermal Conductivity	16
Table 11	Enpure Natural PP Valves	16
Table 12	Pipe insertion length	24
Table 13	Socket Fusion Timing	24
Table 14	American National Standard Taper Pipe Threads (NPT)	32
Table 15	Maximum Pressures for Flanged Systems	33
Table 16	Recommended Torque	34
Table 17	Flange Bolt Set	34
Table 18	Thrust at Fittings in lbs. per 100 psi (internal pressure)	35
Table 19	Maximum Allowable Support Spacing for Enpure Schedule 40.	36
Table 20	Maximum Allowable Support Spacing for Enpure Schedule 80.	36
Table 21	Support Spacing Correction Factors	36

Figures

Figure 1	Dynamic Leach Analysis	5
Figure 2	Dynamic Leach Analysis	5
Figure 3	Pipe Anchor.	15
Figure 4	Rigid Pipe support	37
Figure 5	Recommended Pipe Hangers for Thermoplastic Piping Systems	38

SECTION ONE: GENERAL INFORMATION

OVERVIEW

This manual provides the most up-to-date and comprehensive information about the Enpure high purity piping systems produced by IPEX. Written with the needs of the engineer and contractor in mind, all aspects of High Purity Polypropylene (PP) systems are covered. This includes material properties, specifications, system selection and installation.



BENEFITS

Virgin Material

Enpure is manufactured from special high purity virgin polypropylene materials. No regrind material is used in the manufacturing process, thereby avoiding contamination by colorants or other materials and potential loss of physical properties due to the incorporation of heat stressed materials. To avoid contamination after manufacturing, the pipe is capped and boxed immediately after production.

Extended Life

Once properly selected for the application and correctly installed, Enpure products provide years of maintenance free service. Enpure was first introduced in 1984 and has been operated successfully in demanding high purity and industrial applications for over 23 years.

Lower Costs

IPEX Enpure natural PP has lower material and installation costs than other comparable materials such as stainless steel or PVDF.

Chemical Resistance

Enpure natural PP offers a complete high purity system including pipe, fittings and valves with outstanding resistance to most organic and inorganic chemicals in common use. It is potentially vulnerable to strong oxidizing acids, certain organic solvents and chlorinated hydrocarbons. For specific applications see the IPEX Chemical Resistance Guide.

Biological Resistance

Enpure natural PP piping is resistant to fungi and bacterial growth. The smoothness of the interior walls inhibits bacterial growth by eliminating sites where bacteria can adhere.

Corrosion Resistance

Our thermoplastic materials are immune to damage from naturally corrosive soil conditions as well as electrochemical or galvanic corrosion. These non-corroding properties extend service life and lower maintenance costs even in below-grade applications.

Abrasion Resistance

The inherent abrasion resistance of natural PP allows substantial increases in life expectancy compared to other materials. In many applications, natural polypropylene out-performs other materials such as metals.

Improved Flow

IPEX piping is smooth and has a substantially lower roughness factor than metal and other materials, and since thermoplastics do not rust, pit, scale or corrode, the interior walls remain smooth in virtually any service. This high carrying capacity results in higher flow rates throughout the service life of the application.

Service Temperature

IPEX Enpure line of pipe, fittings and valves are designed to meet the highest purity standards. It is because of this that there are no additives in the virgin polypropylene material. Additives such as antioxidants and UV stabilizers help thermoplastic materials with oxidation resistance. Since Enpure does not contain these additives, it is pressure rated at 73°F (23°C) and will experience lower pressure capabilities and a shortened service life if operated at elevated temperatures.

Note: Estimated service life of PP in elevated temperature operation can be found in ISO 8584-1.

Standards and Approvals

IPEX manufactures the widest range of thermoplastic piping systems available. All products are produced to the strictest internal quality control specifications and meet or exceed applicable regulatory standards.

Enpure natural polypropylene materials are prior sanctioned by the US Food and Drug Administration. (FDA Code of Federal Regulations CFR Title 21 – 177.1520 (2002). This includes Enpure Schedule 40 and Schedule 80 plain end polypropylene pipe materials, as well as all fittings and valves.

Enpure natural polypropylene materials meet or exceed NSF requirements for potable water.

IPEX will assist customers in obtaining additional product approvals that may be required in a particular jurisdiction.

HIGH PURITY SYSTEMS

High purity systems have stringent requirements, whether the application is for ultra pure water or for transporting chemically pure reagents or foodstuffs. The following will focus on high purity water systems, although the same emphasis on purity applies to other applications.

Increasingly, manufacturing industries and research facilities require high purity water systems for their operations. Water purification technologies such as distillation, de-ionization, reverse osmosis and filtration produce purified water, eliminating a variety of impurities such as bacteria, particulates and both organic and inorganic contaminants.

To meet the increased demand for pure water, in many applications a centralized source of high purity water is established on site. The water is produced, stored and distributed on an as needed basis. Often there is a considerable distance from the source of water production to the point of use. In these situations to maintain high standards of water quality, it is very important to select the correct layout design and distribution piping material.

Piping Material

Traditional materials for handling high purity water have been metal piping, principally stainless steel, tin-lined copper and aluminum. These materials can exhibit problems with trace metal contamination (e.g. aluminum, iron, nickel and chromium), degrading water quality and adversely affecting end use applications. Similar contamination problems can be found with glass piping, where elements such as sodium, boron, silica, lead and arsenic can be leached out of the piping. These types of contamination can be avoided by using the proper thermoplastics.

Over the past twenty years, advances in thermoplastic technology have enabled the effective use of plastics for high-purity water distribution systems, even in aggressive ultra high purity installations. In these instances, the water will attempt to leach out any dissolvable elements or ions present in the system, from any of the piping components or other materials present in the system. This aggressive action introduces contaminants that can degrade water quality and can result in deterioration of the piping system itself. PVC may be used for high purity water distribution systems

however it contains additives which are susceptible to leaching. The joining method used with PVC will also contribute to contamination of high purity water. Solvent cement will typically get on the inside of the pipe during installation and then be extracted by the high purity water over time. This same phenomenon occurs to the additives in the pipe material.

The Enpure natural polypropylene line contains very low quantities of leachable elements which are usually removed during pre-rinses of the system at startup. Unlike metal piping, which will continue to be affected by aggressive high purity water after startup, Enpure will not be adversely affected and will provide optimum high purity water quality for the duration of its service life.

Joining Methods

Joining methods should also be considered when reviewing sources of potential contamination. Refer to pg 18 for more details.

Enpure System

IPEX's Enpure piping system is one of the few products that can meet the rigorous demands of high purity applications. Enpure is manufactured from special high purity, natural, polypropylene material that has been successfully used in hospitals, laboratories, universities, chemical and pharmaceutical plants for over two decades (23 years). Its applications can range from distilled water (resistivity of less than 1 meg ohm) through to de-ionized water with a resistivity of 18 meg ohm.

Enpure meets electronics industry E-2 water standards and AAMI dialysis water standards.

To ensure the highest purity possible, the IPEX Enpure system was tested for trace leachables. Testing was conducted by an independent analytical laboratory and a summary of the procedures and findings are provided in tabular and graphical form on the following pages. Also, for comparative analysis, translucent blue PVC, currently promoted for the same application, was tested under identical conditions.

Static Leach Analysis

This test represents a process shutdown scenario where the piping system would be offline for a given amount of time. Higher concentration levels of trace elements would leach out of the piping system due to the stagnant process water.

This test utilized 18.2 MegOhm-cm UPW and Enpure Schedule 80 – 1" diameter by 16" long pipe samples (approximately 47 square inches of wet surface contact area).

The test was performed at 73°F. The test results shown in Tables 1 & 2 detail the trace leachables recorded. Type E-2

Water requirements (Table 1) along with AAMI water requirements (Table 2) are shown as an indicator of suitability for the semiconductor and dialysis industries.

This test was then repeated at elevated temperatures 180°F for Enpure and 140°F for Blue PVC (max for PVC). When temperature is elevated, the leachable concentrations generally increase. At higher temperatures, the Enpure product out performed the Blue PVC for trace leachables.

Table 1: Static Leach Test results comparing Enpure to Translucent Blue PVC and Type E-2 water requirements.

Element	Detection Limit (x10-8)	Type E-2 Water Req. (x10-8)	Enpure x 10-8 @ 73°F	Blue PVC x10-8 @ 73°F
TOC	2	5	5	150
Fluoride	0.2	-	*	*
Chloride	0.02	0.1	*	0.74
Nitrate	0.05	0.1	0.09	*
Phosphate	0.05	0.1	*	*
Sulfate	0.05	0.1	*	0.69
Aluminum	0.005	-	*	*
Arsenic	0.02	-	*	*
Barium	0.001	-	*	0.009
Calcium	0.05	-	*	0.91
Chromium	0.003	-	*	*
Copper	0.005	0.1	*	*
Lead	0.005	-	*	*
Magnesium	0.002	-	*	0.029
Mercury	0.005	-	*	*
Nickel	0.005	0.1	*	*
Potassium	0.01	0.2	*	0.03
Selenium	0.7	-	*	*
Silver	0.003	-	*	*
Sodium	0.006	0.1	*	0.092
Tin	0.002	-	*	0.018
Zinc	0.006	0.1	*	*

- * below detection limit
- not required by test method
- **bold** indicated noncompliance with the standard.

Table 2: Static Leach Test results comparing Enpure, Translucent Blue PVC and AAMI Dialysis

Element	Detection Limit (x10-8)	AAMI Dialysis Req.	Enpure x 10-8 @ 73°F	Blue PVC x10-8 @ 73°F
TOC	2	-	5	150
Fluoride	0.2	200	*	*
Chloride	0.02	-	*	0.74
Nitrate	0.05	2000	0.09	*
Phosphate	0.05	-	*	*
Sulfate	0.05	100000	*	0.69
Aluminum	0.005	10	*	*
Arsenic	0.02	5	*	*
Barium	0.001	100	*	0.009
Calcium	0.05	2000	*	0.91
Chromium	0.003	14	*	*
Copper	0.005	100	*	*
Lead	0.005	5	*	*
Magnesium	0.002	4000	*	0.029
Mercury	0.005	0.2	*	*
Nickel	0.005	-	*	*
Potassium	0.01	8000	*	0.03
Selenium	0.7	90	*	*
Silver	0.003	5	*	*
Sodium	0.006	70000	*	0.092
Tin	0.002	-	*	0.018
Zinc	0.006	100	*	*

- Note:**
1. TOC = total organic carbon
 2. Electronics and semiconductor Type E-2 Water per ASTM D5127-99
 3. Association for the Advancement of Medical Instrumentation (AAMI) guidelines for dialysis water.
- * below detection limit

Dynamic Leach Analysis

This test represents the purging of contaminants in a process line during a start-up phase. Since Ultra Pure Water (UPW) is expensive, the expectation is for these contaminants to fall within acceptable levels as soon as possible. The longer time required for the contaminants to drop in concentration results in added expense and is representative of what will occur every time the system is started up after a shutdown.

The test assembly rig was hooked up to the UPW supply on the upstream side and on the downstream side of the test rig and the water was allowed to "run to drain". The test rig UPW was setup to "run to drain" as a result of the independent test laboratory concerns that the blue PVC would contaminate their piping system rig.

The test utilized 18.2 MegOhm-cm UPW flowing at 1 US gallon per minute (US GPM) & Enpure Schedule 80 - 1" diameter by 48" long pipe samples (approximately 141 square inches of wet surface contact area). The test duration was 4 hours and all UPW, after passing through the test samples was analyzed and then "run to drain".

The particle frequency of 4 sizes, ranging from 0.05 micron up to 0.20 micron(N/mL), were recorded and are presented in Figures 1 & 2.

In both the static and dynamic leach analysis it was found that Enpure PP exceeds the performance of Blue Translucent PVC and meets electronics industry E-2 and AAMI dialysis water standards. Enpure also reduces cost on system start-up and shutdowns of ultra pure water (UPW) since there are less dissolved materials to be leached out of the pipe and joints, As seen in Table 1 and Table 2. Figure 1 and Figure 2 show that it takes much less time for the particle count to approach Zero (0) with Enpure pipe compared to Translucent PVC. At a cost of approximately \$10/ L for UPW this becomes a valuable asset.

Figure 1: 0.05 micron particle count during successive 20 minute intervals over a four hour time period

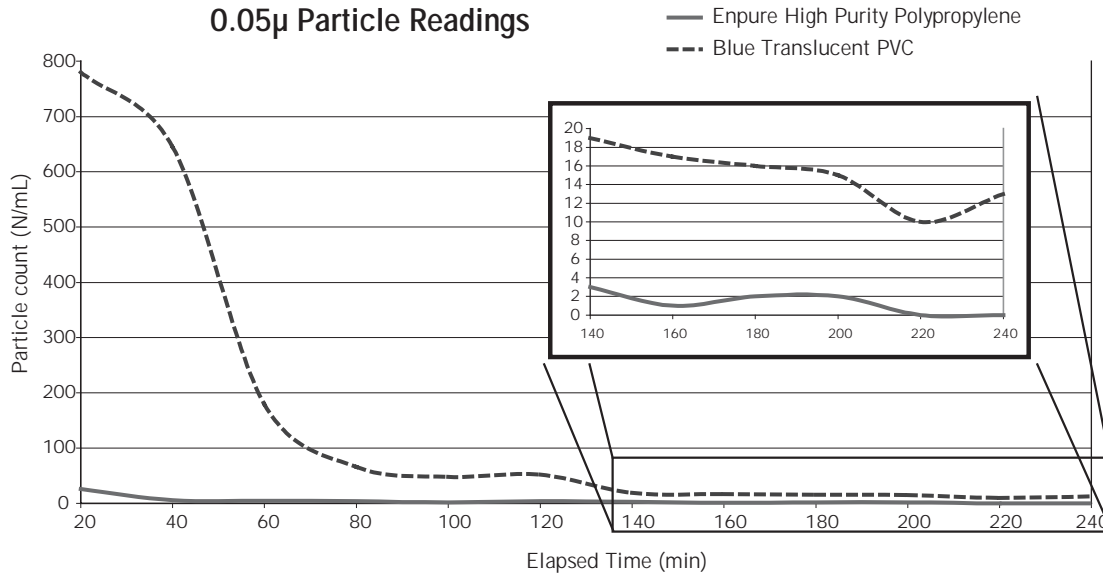
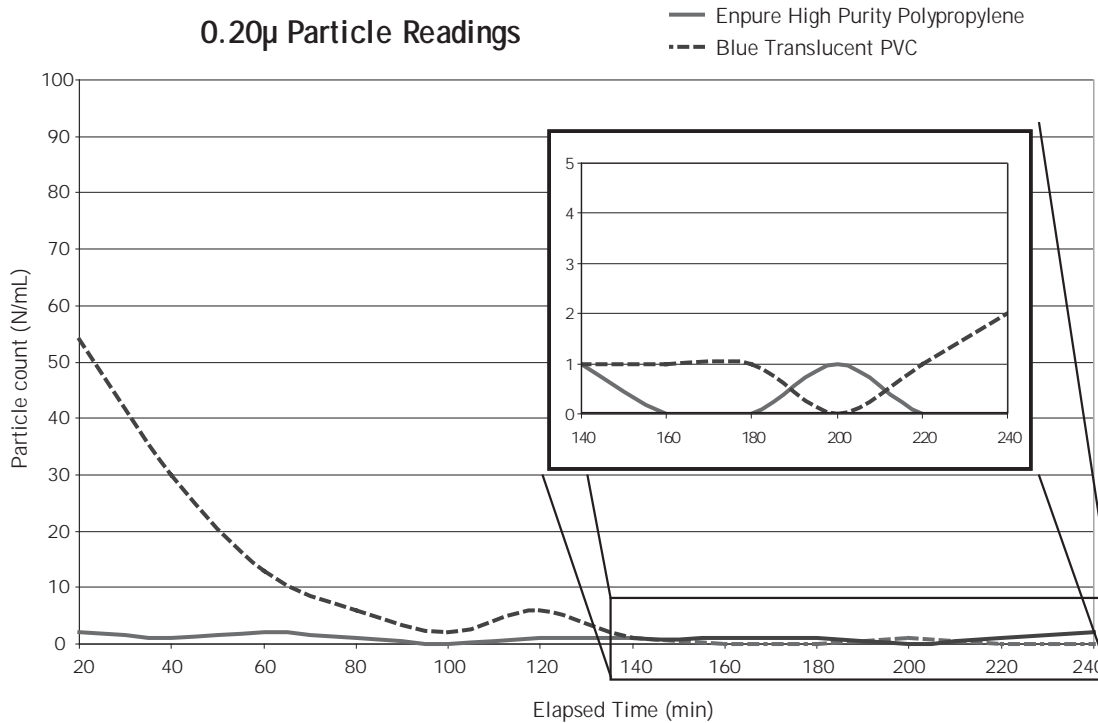


Figure 2: 0.20 micron particle count during successive 20 minute intervals over a four hour time period



MATERIAL DESCRIPTION

PP (Polypropylene)

Enpure is manufactured from a selection of pure virgin polypropylene with no added plasticizers, pigments or re-grind. The material is a lightweight polypropylene conforming to ASTM D4101 that is chemically resistant to organic solvents as well as acids and alkalis. It is vulnerable to strong oxidizing acids, chlorinated hydrocarbons and aromatics and

is not recommended for these systems. Polypropylene has proven to be an excellent material for high purity water systems and industrial drainage systems where mixtures of acids, bases and solvents are involved. Enpure pipe, fittings and valves are joined by socket fusion. Flanging and mechanical joints are also available.

Table 3 – Physical Properties

PROPERTIES	MATERIALS	
	Natural PP	Standards
Specific Gravity	0.905	ASTM D792
Tensile Strength at Yield (psi)	3,900	ASTM D638
Modulus of Elasticity Tensile (psi) at 73°F (23°C)	180,000 - 190,000	ASTM D638
Flexural Strength (psi)	7,000	ASTM D790
Izod Impact, (ft.lbs./in.) at 73°F (23°C), notched	no break	ASTM D256
Compressive Strength (psi)	5,500 - 8,000	ASTM D695
Poisson's Ratio	0.38 - 0.40	
Coefficient of Linear Expansion (in./in./°F x 10 ⁻⁵)	6.1	ASTM D696
Linear Expansion Factor, (in./100 ft./10°F)	0.732	
Maximum Operating Temperature, (°F)	180	
Heat Distortion Temperature, (°F) at 264 psi	125 - 140	ASTM D648
Thermal Conductivity, (BTU/in./hr./sq.ft./°F)	1.2	ASTM C177
Water Absorption, (%) 24 hrs. at 73°F (23°C)	0.02	ASTM D570

APPLICATIONS

Empure's superior chemical and physical properties, plus ease of installation, make it an ideal piping system for conveying acids, alkalis, solvents and deionized water, distilled water, brine, caustic soda and other liquids where high purity and chemical resistance capability is required. It has particular applications in industries such as:

- Chemical Manufacturing
- Food Processing
- Pharmaceutical Manufacturing
- Hospitals
- Laboratories
- Universities
- Research Facilities
- Photographic chemical processing
- Biotechnology
- Effluent treatment plants
- Water treatment plants



SECTION TWO: PROCESS PIPING DESIGN

INTRODUCTION

Thermoplastics are engineered materials that are suitable for a wide variety of piping assignments in process applications. To effectively implement the use of plastics in high purity applications, it is considered necessary to have both a working knowledge of piping design and an appreciation of the unique properties of thermoplastics.

This section will review the design process and consider the most important factors in designing plastic piping systems.



DESIGN PROCESS

Establish System Requirements

Before the proper materials can be chosen, the system design requirements must be determined. This establishes the scope of the project and determines design and material specifications. Factors to be considered, but not limited to, include:

1. Liquid composition
 - Chemical characteristics
 - Variations in fluid chemistry
2. Process flow
 - Required flow rate
 - Required pressure
 - Changes in velocity
 - Potential pressure drops
 - Potential pressure surges
 - Minimum and maximum operating temperatures
3. System Location / Environment
 - Above / below ground or overhead
 - Climate (extreme heat or cold)
 - Expected fluctuations in ambient temperature
4. Installation
 - Space restrictions
 - Difficult access
 - New or retrofit
 - Joining of dissimilar materials
5. Budget Considerations
 - Material cost
 - Installation cost
 - Maintenance cost
 - Lifetime cost

Determine Appropriate Sizing

In addition to accounting for specific system parameters, pipe size must also be determined. To select appropriate size, it is essential that there is an understanding of the most important physical factors affecting thermoplastic pipe, which are:

- a) pressure limitations
- b) frictional loss
- c) temperature limitations
- d) the pressure/temperature relationship

A) Pressure Limitations

Pressure Ratings

PP process pipe is primarily designed to withstand internal pressure under continuous or steady state loading. Short term higher pressure bursts or surges can be accommodated to varying degrees, but it is the long term strength of the material that determines its performance.

Determining Pressure

The carrying capacity of any pipe is a function of its hoop strength and the geometry of the pipe as defined by its wall thickness and diameter at a given temperature. Maximum operating pressures for Enpure PP pipe and fittings are given in Table 4.

Table 4 – Pressure Ratings for Enpure Schedule 40 & Schedule 80 PP pipe (psi)

Size (in.)	Sch 40 PP 73°F (23°C)	Sch 80 PP 73°F (23°C)
1/2	120	150
3/4	120	150
1	120	150
1-1/4	120	150
1-1/2	120	150
2	120	150
3	80	115
4	80	115

B) Friction Loss through Piping

As fluid flows through a piping system, it will experience friction resistance between the fluid and the pipe wall resulting in a pressure loss. This is a result of fluid:

- density
- viscosity
- velocity
- temperature
- type of flow
- smoothness of the pipe wall.

Friction loss can be determined by referring to published tables, such as those in Tables 5 and 6 or it can be calculated. The most widely used equation to calculate friction loss under pressure is the Hazen-Williams equation.

Hazen-Williams

$$f = 0.2083 \times (100/C)^{1.852} \times \frac{Q^{1.852}}{Di^{4.8655}}$$

where:

- f = friction loss (ft. of H₂O/100 ft.)
- Q = flow rate (gpm)
- Di = pipe inside diameter (in.)
- C = flow coefficient (constant at 150 for PP)

Table 5 – Carrying Capacity and Friction Loss for Schedule 40 Thermoplastic Pipe

GPM	1/2"			3"			3/4"			1"			1-1/4"			1-1/2"			2"			
	Velocity (ft/s)	Friction Head (ft)	Friction Loss (psi)	Velocity (ft/s)	Friction Head (ft)	Friction Loss (psi)	Velocity (ft/s)	Friction Head (ft)	Friction Loss (psi)	Velocity (ft/s)	Friction Head (ft)	Friction Loss (psi)	Velocity (ft/s)	Friction Head (ft)	Friction Loss (psi)	Velocity (ft/s)	Friction Head (ft)	Friction Loss (psi)	Velocity (ft/s)	Friction Head (ft)	Friction Loss (psi)	
1	1.13	1.16	0.50																			
2	2.26	4.19	1.81																			
5	5.64	22.88	9.90																			
7	7.89	42.66	18.47																			
10																						
12																						
15																						
20																						
25																						
30	1.55	0.32	0.14																			
35	1.77	0.41	0.18																			
40	1.99	0.51	0.22																			
45	2.21	0.61	0.27																			
50	2.43	0.73	0.32																			
55	2.65	0.86	0.37																			
60	2.87	1.00	0.43																			
65	3.09	1.15	0.50																			
70	3.31	1.30	0.56																			
75	3.53	1.47	0.63																			
80	3.75	1.64	0.71																			
90	3.97	1.82	0.79																			
100	4.20	2.02	0.87																			
125	4.42	2.22	0.96																			
150	5.52	3.35	1.45																			
175	6.62	4.70	2.03																			
200	7.73	6.25	2.71																			
250	8.83	8.00	3.46																			
300	11.04	12.10	5.24																			
350																						
400																						
450																						
500																						

Table 6 – Carrying Capacity and Friction Loss for Schedule 80 Thermoplastic Pipe

GPM	1/2"			3/4"			1"			1-1/4"			1-1/2"			2"		
	Velocity (ft/s)	Friction Head (ft)	Friction Loss (psi)	Velocity (ft/s)	Friction Head (ft)	Friction Loss (psi)	Velocity (ft/s)	Friction Head (ft)	Friction Loss (psi)	Velocity (ft/s)	Friction Head (ft)	Friction Loss (psi)	Velocity (ft/s)	Friction Head (ft)	Friction Loss (psi)	Velocity (ft/s)	Friction Head (ft)	Friction Loss (psi)
1	1.48	2.24	0.97	1.57	1.73	0.75	0.93	0.49	0.21	1.30	0.64	0.28	1.31	0.54	0.24	1.68	0.63	0.27
2	2.95	8.10	3.51	3.92	9.47	4.10	2.33	2.67	1.16	1.82	1.20	0.52	1.88	1.05	0.46	2.23	1.07	0.47
5	7.39	44.21	19.14	5.49	17.65	7.64	3.27	4.98	2.16	2.59	2.32	1.00	2.25	1.47	0.64	2.79	1.63	0.70
7	10.34	82.43	35.69	7.84	34.18	14.79	4.67	9.65	4.18	3.11	3.25	1.40	2.81	2.23	0.96	3.35	2.28	0.99
10				9.41	47.90	20.74	5.60	13.52	5.85	3.89	4.91	2.12	2.81	2.23	0.96	3.91	3.03	1.31
12				11.76	72.42	31.35	7.00	20.44	8.85	5.19	8.36	3.62	3.75	3.80	1.64	4.47	3.88	1.68
15							9.33	34.82	15.07	6.49	12.64	5.47	4.69	5.74	2.48	5.03	4.83	2.09
20							11.66	52.64	22.79	7.78	17.71	7.67	5.63	8.04	3.48	5.58	5.87	2.54
25										9.08	23.56	10.20	6.57	10.70	4.63	6.14	7.00	3.03
30	1.49	0.32	0.14							10.38	30.17	13.06	7.50	13.71	5.93	6.70	8.22	3.56
35	1.74	0.43	0.18										8.44	17.05	7.38	7.82	10.94	4.74
40	1.99	0.54	0.24										9.38	20.72	8.97	8.38	12.43	5.38
45	2.24	0.68	0.29										10.32	24.72	10.70	8.93	14.01	6.06
50	2.49	0.82	0.36										9.70	20.22	8.75	10.05	17.42	7.54
55	2.74	0.98	0.43										10.51	23.45	10.15	11.17	21.18	9.17
60	2.99	1.15	0.50										11.32	26.90	11.65			
65	3.24	1.34	0.58															
70	3.49	1.54	0.66															
75	3.74	1.74	0.76															
80	3.99	1.97	0.85															
90	4.48	2.45	1.06															
100	4.98	2.97	1.29															
125	6.23	4.49	1.95															
150	7.47	6.30	2.73															
175	8.72	8.38	3.63															
200	9.97	10.73	4.65															
250																		
300																		
350																		
400																		
450																		
500																		

Friction Loss through Fittings

Friction head loss also occurs through fittings. Friction loss through fittings is expressed in equivalent feet of straight pipe that would produce the same friction loss. Values for friction loss through various fittings are given in Table 7.

**Table 7 – Friction Loss through Fittings
(in equivalent feet of pipe)**

Size (in.)	Fittings			
	Tee Run	Tee Branch	90° Elbow	45° Elbow
1/2	1.0	3.8	1.5	0.8
3/4	1.4	4.9	2.0	1.1
1	1.7	6.0	2.5	1.4
1-1/4	2.3	7.3	3.8	1.8
1-1/2	2.7	8.4	4.0	2.1
2	4.0	12.0	5.7	2.6
3	6.1	16.4	7.9	4.0
4	7.9	22.0	11.4	5.1

Friction Loss through Valves

Pressure drops through valves also contribute to the overall friction loss of fluid through a piping system. Flow rate coefficients (C_v) are defined as the flow rate in gallons per minute (gpm) through an open valve required to produce a pressure drop of 1 psi. Flow rate coefficients are listed in the Valve section of this manual and can also be calculated using the following formula.

$$f = sg (Q / C_v)^2$$

Where:

- f = pressure drop (friction loss) across the valve (psi)
- Q = flow through the valve (gpm)
- sg = specific gravity (*water = 1.0)
- C_v = flow rate coefficient

Ball Valves C_v information is available on page 42

Diaphragm Valves C_v information is available on page 44

Check Valves C_v information is available on page 46

C) Temperature Limitations

Thermoplastic materials have physical limitations as to the operating temperatures they can withstand. The limitations are often altered using additives. Enpure virgin polypropylene has an operating temperature range between -20°F (-29°C) and 73°F (23°C) and is able to operate up to 180°F (82°C) with a shortened life span.

Note: Estimated service life of PP in elevated temperature operation can be found in ISO 8584-1.

D) Pressure/Temperature relationship

Thermoplastic material strength is sensitive to temperature. Standard PP pipe pressure ratings are determined at an ambient temperature of 73°F (23°C). Generally, as the operating temperature falls below the basis temperature of 73°F (23°C), there is an increase in hoop strength and a subsequent increase in pressure rating. However, as the operating temperature rises above ambient temperature, strength decreases. In the former, usually no consideration is made to the design process and the incremental strength is considered part of the safety factor. However, compensation should be made for operating temperatures above 73°F. As temperature increases, you must reduce the pressure rating.

DESIGN CONSIDERATIONS

Expansion and Contraction

All piping products expand and contract with changes in temperature. Linear expansion and contraction of any pipe on the longitudinal axis relates to the coefficient of thermal expansion (e) for the specific material used in the manufacturing of the product. Variation in pipe length due to thermal expansion or contraction depends on the linear expansion factor (Y) and the variation in temperature irrespective of wall thickness.

Table 8 – Coefficients of Thermal Expansion

Piping Material	e Thermal Expansion Coefficient (in./in./°F)	Y Linear Expansion Factor (in./100ft./10°F)
PP	6.1 x 10 ⁻⁵	0.732

The length change due to thermal expansion or contraction depends on the system temperature differential, as well as the length of pipe run between changes in direction. Values for thermal expansion for PP pipe are given in Table 9. Expansion can also be calculated using the following formula:

$$\Delta L = \frac{Y (T - F) \times L}{10 \times 100}$$

where:

ΔL = change in length (in.)

Y = linear expansion factor (inches of expansion per 10°F temperature change per 100 ft. of pipe)

T = maximum temperature (°F)

F = minimum temperature (°F)

L = length of pipe run (ft)

When total temperature change is less than 30°F, special provisions for accommodating thermal expansion are not generally required, especially when the line includes several directional changes. There is considerable inherent flexibility in the piping system.

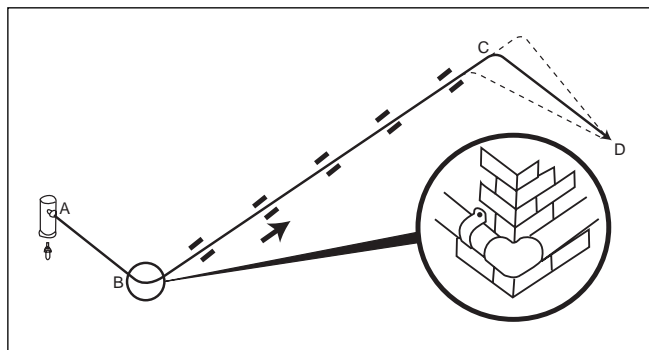
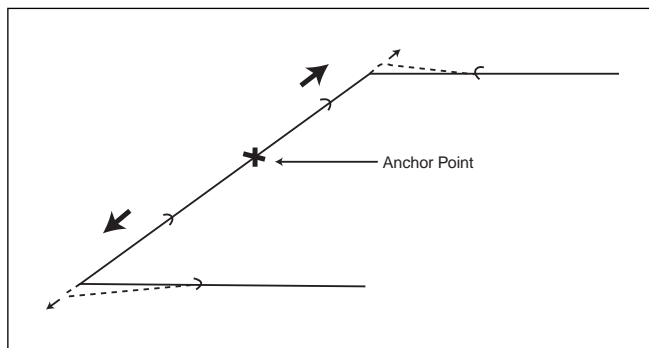
Note: Remember to allow for contraction when piping is to be exposed to temperatures substantially below installation temperature.

Table 9 – PP Linear Expansion (ΔL) in inches

Temp. change (°F)	Length of Run (ft)									
	10	20	30	40	50	60	70	80	90	100
10	0.07	0.02	0.22	0.29	0.37	0.44	0.51	0.59	0.66	0.73
20	0.15	0.29	0.44	0.59	0.73	0.88	1.02	1.17	1.32	1.46
30	0.22	0.44	0.66	0.88	1.10	1.32	1.54	1.76	1.98	2.20
40	0.29	0.59	0.88	1.17	1.46	1.76	2.05	2.34	2.64	2.93
50	0.37	0.73	1.10	1.46	1.83	2.20	2.56	2.93	3.29	3.66
60	0.44	0.88	1.32	1.76	2.20	2.64	3.07	3.51	3.95	4.39
70	0.51	1.02	1.54	2.05	2.56	3.07	3.59	4.10	4.61	5.12
80	0.59	1.17	1.76	2.34	2.93	3.51	4.10	4.68	5.27	5.86
90	0.66	1.32	1.98	2.64	3.29	3.95	4.61	5.27	5.93	6.59
100	0.73	1.46	2.20	2.93	3.66	4.39	5.12	5.86	6.59	7.32

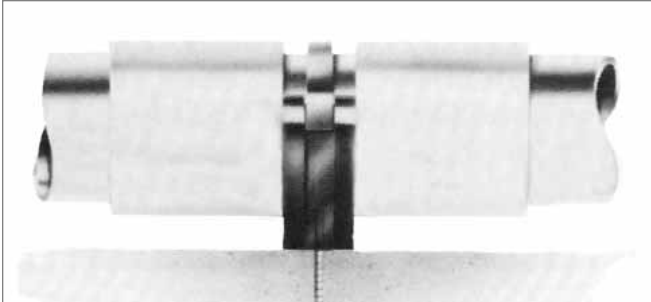
Support

In terms of support, expansion can be accommodated by a combination of pipe anchor and guide points and the natural flexibility of Enpure piping.



Pipe anchors can be either at natural anchor points or be introduced into the system. Natural anchors include pipe clips placed at strategic points in the system. For example, at connections to fixed equipment, such as large filters. Other anchors can be introduced to restrain pipe by using pipe clips and couplings as shown in Figure 3. These anchors restrain the pipe without gripping or compressing it.

Figure 3 - Pipe Anchor



Water Hammer/ Hydraulic Shock

Surge pressures due to water hammer should be considered when designing a piping system. A momentary pressure rise occurs when the flow of liquid is started and stopped quickly, as a result of the fluid's momentum. Pressure rise increases with the velocity of the liquid, the length of the piping system from the liquid source, or with an increase in the speed of starting or stopping. Examples of hydraulic shock occur when valves are opened or closed quickly, or pumps are started with an empty discharge line. Proper design when laying out a piping system will eliminate the possibility of hydraulic shock damage. The following suggestions will help avoid problems:

1. In any piping system, including thermoplastic, a liquid velocity not exceeding 5 ft./sec. will lessen hydraulic shock effects, even with quick-closing valves (e.g. solenoid valves).
2. Using actuated valves with a specific closing time will reduce the possibility of inadvertent opening or closing of a valve too quickly. With pneumatic and air-spring actuators, it may be necessary to place a valve in the air line to slow down the valve operation cycle.
3. Evaluate flow at pump start-up and during spin-down. Also determine how much air, if any, is introduced during pump start-up.
4. If possible, when starting a pump, partially close the valve in the discharge line to minimize the volume of liquid that is rapidly accelerated through the system. Once the pump is up to speed and the line completely full, the valve may be slowly opened.
5. Use surge control devices wisely to give flow storage during surge and to minimize column separation. Check valves can be used near pumps to help keep lines full.

Calculations used to predict water hammer are based on elastic wave theory. The formula for calculating the surge pressure for any liquid assuming instantaneous valve closure is:

$$a = \frac{12 \times [k/\delta]^{0.5}}{[1 + (K/E) \times (DR-2)]^{0.5}}$$

$$SP = \frac{a \times v \times Df}{144 \times g}$$

where:

- a = Pressure Wave Velocity, ft/s
- DR = Dimension Ratio = Pipe O.D./Minimum Wall Thickness
[{(Inside Diameter + (2 x Average Wall Thickness)) / Minimum Wall Thickness}]
- E = Modulus of elasticity of the pipe material, psi
- g = Acceleration due to gravity, 32.172 Ft/s/s
- K = Bulk modulus of the fluid, psi
- SP = Surge pressure, psi
- Df = Density of fluid, lb/ft³
- δ = (Density (Df), lb/ft³) / (Gravity (g), Ft/s/s), slugs/ft³
- v = Change in flow velocity, distance/time or volume/time

The Hoop Stress is calculated by the equation:

$$S = \frac{SP \times (DR-1)}{2}$$

where:

- S = Hoop Stress in the pipe wall, psi
- DR = Dimension Ratio = Pipe O.D./Minimum Wall Thickness
[{(Inside Diameter + (2 x Average Wall Thickness)) / Minimum Wall Thickness}]
- SP = Surge pressure, psi

To prevent rapid valve closure from creating high surge pressures, the minimum closure time of a valve can be calculated. The following formula would apply.

$$T = \frac{2 \times L}{a}$$

where:

- T = minimum closure time (sec)
- L = length of pipe from valve to point of relief (ft)
- a = velocity of fluid (ft/sec)

Thermal Conductivity

Compared with traditional pipe materials, the thermal conductivity of thermoplastics are low and they essentially act as an insulator. This insulating property provides a distinct advantage over traditional materials to prevent "sweating" or formation of condensation on the pipe wall. The need for insulation may, in certain instances, be completely eliminated. Thermal conductivity for various material types is shown in Table 10.

Table 10 – Coefficients of Thermal Conductivity

Material	BTU in./hr. ft ² °F
PP	1.20
PVC	1.20
CPVC	0.95
Glass	8.0
Carbon Steel	360
Aluminum	1,000
Copper	2,700

Valves

Valve Selection

As is the case with other thermoplastic components in a processing system, a valve must be selected based on the characteristics of the fluid medium, the system's operating parameters, and its intended function for a particular application. Certain valve types are more suitable than others for on/off service, throttling or modulating, automation, back flow prevention, etc. Table 11 summarizes the valves offered as part of the Enpure system.

Some other considerations that may be important when selecting a valve include: physical space requirements or constraints, connection style, manual or remote operation, as well as position indication or feedback.

Automated Valves

IPEX can provide quarter turn pneumatic or electric actuators and mounting assemblies for Enpure ball valves. Pneumatic actuator bonnets are also available for Enpure diaphragm valves. A wide selection of accessories such as pilot solenoid valves, position indicators, and microswitches, allow various control and feedback options. Please refer to the Thermoplastic Valves and Quarter Turn Automation literature or contact IPEX for further details regarding availability.

Table 11 - Enpure Natural PP Valves

Valve Type	Sizes	Materials	Connections/Style	Pressure Rating (psi) at 73°F
VKD Series Ball Valves	1/2 - 2	Natural PP	Socket, Flange	150
VM Series Diaphragm Valves	1/2 - 2	Natural PP	Socket, Flange	150
SR Series Ball Check Valves	1/2 - 2	Natural PP	Socket, Flange	150

SECTION 3: INSTALLATION

INTRODUCTION

Proper installation is key to producing a stable and robust system. The following section will outline all installation guidelines for our Enpure High Purity PP system.

HANDING AND STORAGE

PP is a strong, lightweight material, about one eighth the weight of steel or cast iron. Piping made of this material is easily handled and, as a result, there is a tendency for them to be thrown about on the jobsite. Care should be taken in handling and storage to prevent damage to the pipe.

Keep all Enpure pipe and fittings boxed or bagged until ready to use to avoid contamination. If loose pieces are left over, cover then rebag to avoid contamination. Note that all Enpure material should be kept covered and clean to avoid contamination before, during and after use.

Since the soundness of any joint depends in part on the condition of the pipe end, care should be taken in transit, handling and storage to avoid damage to these ends. Care should be taken when unloading and handling pipe in cold weather. Dropping pipe from a truck or forklift may cause damage. Methods and techniques normally used in warm weather may not be acceptable at the lower temperature range.

When loading pipe onto vehicles, care should be taken to avoid contact with any sharp corners (i.e. angle irons, nail heads, etc.), as the pipe may be damaged.

While in transit, pipe should be well secured and supported over the entire length and should never project unsecured from the back of a trailer.

Prolonged Outdoor Exposure

Unpigmented natural polypropylene is affected by ultraviolet light and may become brittle after long-term exposure. Enpure should not be used outdoors unless it is protected by an insulated covering or is painted using paints appropriate for plastics.

JOINING METHODS - SOCKET FUSION

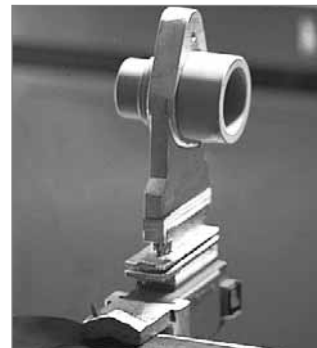
Socket fusion welding involves fusing the pipe to the socket of the fitting. The joint is made by simultaneously fusing the male and female surfaces by special manual or automatic heating devices. The welding tool in its simplest form consists of a heating surface on which a series of heater bushings are mounted; and a heater system, with an automatic temperature controller. No additional materials are required for this type of welding. Socket welding does not affect the chemical resistance of the polypropylene, nor does it influence the chemical resistance or pressure resistance of the assembled pipe, fittings and valves.

There are two different tools available for socket fusion: a hand-held tool and a bench fusion machine. When any of the following is required – larger sizes, high volume joints per day or absolute consistency of the welds – the use of a bench fusion machine (manual or hydraulic) is recommended. Below are detailed instructions for the use of both our hand-held tool and the manual version of the bench fusion machine.

It is strongly recommended that your local IPEX representative demonstrate the socket fusion procedure

before you attempt to assemble the Enpure system. Use only IPEX socket fusion tools. They are designed specifically for our systems, with components that are dimensionally matched. Do not attempt to install a system of mixed brands.

Joining methods should also be considered when reviewing sources of potential contamination. Not all joining methods are equal. Some joining methods can introduce contaminants into the system that are not introduced by the pipe material itself. Below is a breakdown of the most common joining methods and their potential affects on purity. To ensure a contamination-free system, Enpure utilizes a socket fusion joining method.



Purity Level	Joining Methods	Description
•	Threaded Metal Joints	Threaded metal components may cause leaching of contained metals, local stagnation of fluid flow and may produce potential sites for bacterial growth when used with high purity water.
• •	Soldered Metal Joints	Oxidation at welded, braised or soldered metal joints can cause contamination when exposed to the high purity water.
• • •	Solvent Welded Joints	Solvent welded plastic joints, unless carefully made and cured, can contribute contamination to high purity water.
• • • •	Socket Fusion	Socket fusion is a simple process of melting and fusing components together resulting in a clean homogeneous joint. As no compounds are used in the process, sources of material contamination are eliminated. For these types of applications, socket fusion is the joining method of choice.

Socket Fusion Tool

IPEX offers two portable fusion machines for easy assembly of our PP systems. Both are a paddle type fusion machine and are available on their own or as a complete kit with bushings.



1/2" to 2" Fusion Kit



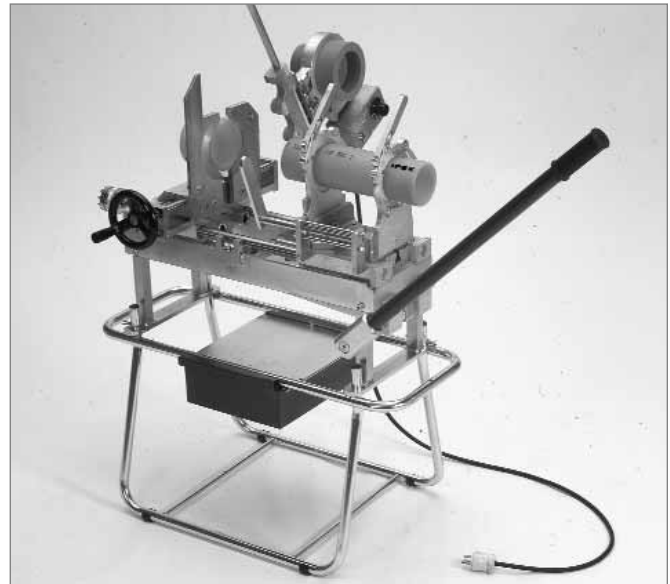
1/2" to 4" Fusion Kit

Socket Fusion Tool Kit c/w Full Set of Heater Bushings 110V, 50Hz			
Dimension (inches)	Output (watts)	Weight In Case (lbs)	Kit Dimensions (inches)
1/2 - 2	800	11	10.6 x 17.7 x 4.3
1/2 - 4	1600	15.5	18.5 x 12.6 x 4.3

Bench Fusion Machine

The IPEX Bench Fusion Machine can be used to efficiently and easily join the Enpure PP system. The kit includes a self-aligning frame and a removable stand with a tool box that contains the necessary tools; thermostat-controlled heating mirror, master pipe, fitting clamps, reducers, heater bushings and patented insertion-depth selector.

The Bench Fusion machine is the natural choice when performing larger size socket welds or when completing a large number of welds requiring consistent and maximum accuracy.



Socket Fusion Tool Kit c/w Full Set of Heater Bushings 110V, 50Hz		
Dimension (inches)	Output (watts)	Weight (lbs)
1/2 - 4	1600	155

INSTALLATION

Socket Fusion with Hand Held Tools

The method described here applies only to thermal welds using manual-type welding equipment.

STEP 1: PREPARATION

Select the heater bushing and the heating spigot of the required diameters, insert and secure the bushings to the heating paddle.



STEP 2: CLEAN SURFACES

Carefully clean the Teflon® coated contact surfaces. Use only a clean dry cloth.



STEP 3: HEATING TOOL

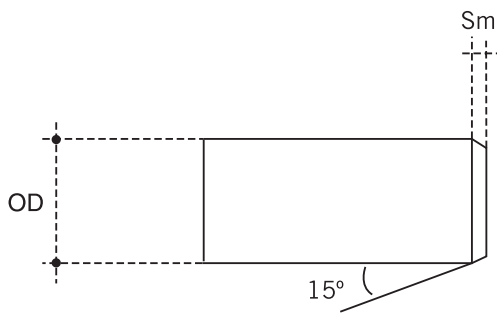
Set the temperature of the heating tool. To form the joint correctly, the temperature should be between 480°F (250°C) and 520°F (270°C). Plug the heater into a grounded 110-volt outlet ensuring that the outlet is protected by circuit breakers or fuses.

Caution: Handle the heater bushings carefully. Damage to the Teflon coating on the heater bushings can result in irregular heating resulting in inferior joints.

Note: Using other electrical devices on the same power source causes amperage loss resulting in poor welds.

STEP 4: CUT PIPE

Cut the pipe at right angles and chamfer the newly cut edge at an angle of 15° and a depth as per the following table.



Pipe Size OD (in.)	Chamfer Depth Sm (in.)
1/2	5/32
3/4	
1	
1-1/4	
1-1/2	
2	3/16
3	
4	

INSTALLATION

STEP 5: CHECK FIT

Check pipe and fittings for dry fit before fusing together.

STEP 6: MAKE INSERTION REFERENCE

The length of pipe to be inserted varies by the pipe diameter. For the correct length of insertion, refer Table 12 (page 24). Once selected, mark the pipe at the correct insertion length L.



STEP 7: MAKE LONGITUDINAL REFERENCE

Mark a longitudinal reference line on the outside of the pipe and the fitting to show a guideline to prevent the two parts from rotating while the joint is being made.



STEP 8: CLEAN PIPE AND FITTING

Clean the fitting and pipe of any traces of oil or grease on the weld surfaces with an approved cleaning agent such as isopropyl alcohol.



STEP 9: CHECK BUSHINGS TEMPERATURE

Check that the thermostat green light is on steady or, if external conditions require the use of a Tempilstik*, use the correct Tempilstik to check the bushings temperature.

CAUTION: DO NOT USE THE STICK ON THE PARTS OF THE BUSHINGS THAT WILL COME IN CONTACT WITH PIPE, FITTINGS OR VALVES.

NOTE: If creating a joint in cold weather, double-check the thermostat reading with the Tempilstik. Should the Tempilstik indicate an insufficient tool temperature, simply increase the thermostat setting by small increments until the Tempilstik deposit on the tool evaporates. After any changes to the temperature dial, the red light will come on. You must wait for the green indicator light before using the Tempilstik.

NOTE: Overheating or underheating of the pipe and fittings may result in a poor joint.



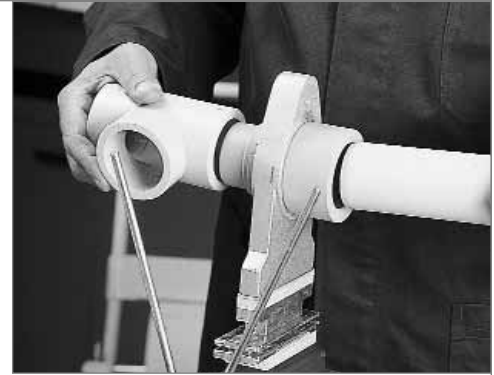
STEP 10: HEAT COMPONENTS

Briefly and simultaneously engage both pipe and fitting with their respective bushing to determine interference. If substantially more resistance is offered by either the pipe or the fitting, begin your insertion with just that one item. Start the insertion of the second item once the first has reached the bushing half point. If the same resistance is observed, start both pipe and fitting insertion simultaneously.

Once the mark on the pipe reaches the edge of the female bushing, and the top of the fitting reaches the stop on the male bushing, apply just enough pressure to prevent "kickback" and hold together for the recommended times as shown in Table 13.

Note: Heating time starts from the moment of full insertion of both pipe and fitting.

Note: If the pipe and fitting do not fit tightly on the heater bushing, heating time should start when the components have swelled to just contact the surface of the heater bushings.



STEP 11: ASSEMBLY

Once the recommended heating time has elapsed, quickly remove the elements from the heater bushings and fit the pipe into the socket for the entire insertion length as determined and marked previously. **Do not turn the pipe in the socket.**

Ensure the longitudinal reference marks are perfectly aligned.



STEP 12: ASSEMBLY

Hold the joint together for the welding time shown in Table 13. This will allow sufficient time for the components to fuse together.



Step 13: Joint Setting

Leave the joint to cool slowly at ambient temperature for the recommended cooling time minimums as shown in Table 13. Allow for proper cooling before pressurizing and testing the system.

NOTE: Never dip the joint into water or expose it to a forced airstream in order to cool it quickly as this will result in weak joints.



Table 12 – Pipe Insertion Length

Pipe Size (in.)	Insertion Length L (in.)
1/2	0.59
3/4	0.70
1	0.78
1-1/4	0.78
1-1/2	0.90
2	0.98
3	1.30
4	1.40

Table 13 – Socket Fusion Timing

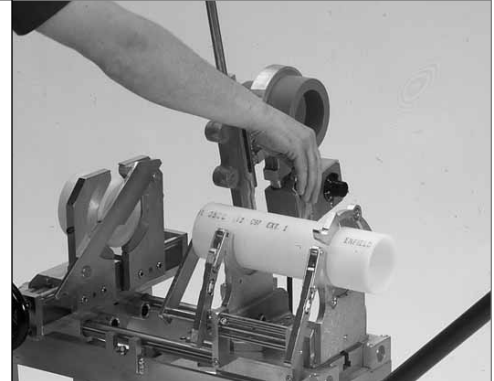
Pipe Size (in.)	Heating Time at 500°F (260°C) (sec)	Welding Time (sec)	Cooling Time	
			(sec)	(min)
1/2	10	4	120	2
3/4	10	4	120	2
1	12	6	240	4
1-1/4	12	6	240	4
1-1/2	16	6	240	4
2	24	8	360	6
3	30	8	360	6
4	35	10	480	8

Socket Fusion with the Bench Fusion Machine

Step 1: Machine Preparation

Assemble the machine and stand, at the work area. Select the correct size of V-blocks for the fittings. Select the inserts for the pipe clamps and fasten them in place using the allen wrench provided.

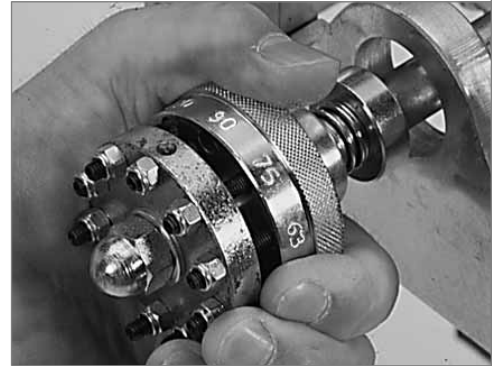
Note: Inserts are not required for 4" pipe.



Step 2: Machine Preparation

Set the insertion depth selector stop on the end of the machine to the correct size as per the following table.

Pipe Size (in.)	Depth Selector Settings
1/2	20
3/4	25
1	32
1-1/4	40
1-1/2	50
2	63
3	90
4	110



Step 3: Prepare Heating Tool

Clean the mirror. Dirty or greasy mirror surfaces will reduce heat transfer and result in inferior joints.

Step 4: Prepare Heating Tool

Bolt the heater bushings securely to the mirror with the hardware provided. Plug the heater into a grounded 110-volt outlet ensuring that the outlet is protected by circuit breakers or fuses.

Caution: Handle the heater bushings carefully. Damage to the Teflon coating on the heater bushings can result in irregular heating resulting in inferior joints.

Note: Using other electrical devices on the same power source causes amperage loss resulting in poor welds.

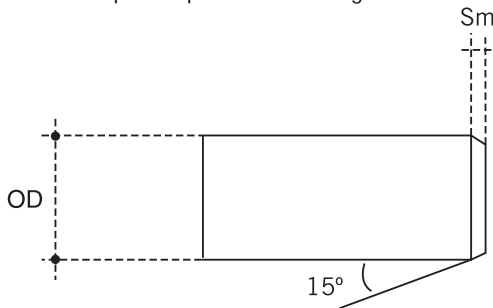
Step 5: Prepare Heating Tool

Set the temperature of the heating tool. To form the joint correctly, the temperature should be between 480°F (250°C) and 550°F (288°C).



Step 6: Cut Pipe

Cut the pipe at right angles and chamfer the newly cut edge at an angle of 15° and a depth as per the following table.



Pipe Size OD (in.)	Chamfer Depth Sm (in.)
1/2	5/32
3/4	
1	
1-1/4	3/16
1-1/2	
2	
3	
4	



Step 7: Check Fit

Check pipe and fittings for dry fit before fusing together.

Step 8: Clean Pipe

Clean the fitting and pipe of any traces of oil or grease on the weld surfaces with an approved cleaning agent such as isopropyl alcohol.



Step 9: Check Bushings Temperature

Check that the thermostat green light has come on. If external conditions require the use of a Tempilstik*, use the correct Tempilstik to check the bushings temperature.

CAUTION: DO NOT USE THE STICK ON THE PARTS OF THE BUSHINGS THAT WILL COME IN CONTACT WITH PIPE, FITTINGS OR VALVES.

If creating a joint in cold weather, double-check the thermostat reading with the Tempilstik. Should the Tempilstik indicate an insufficient tool temperature, simply increase the thermostat setting by small increments until the Tempilstik deposit on the tool evaporates. After any changes to the temperature dial, the red light will come on. You must wait for the green indicator light before using the Tempilstik.

NOTE: Overheating or underheating of the pipe and fittings may result in a poor joint.



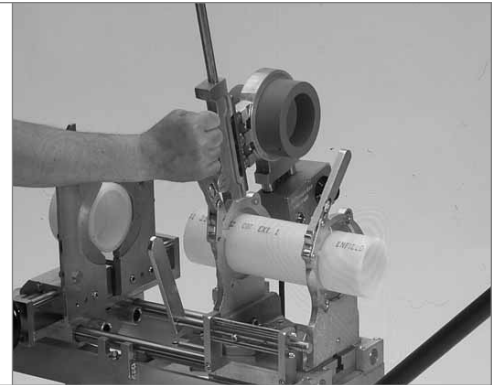
Step 10: Position Components

Position the fitting in the V-blocks on the left side of the machine and flush with the crossbar. Tighten the clamps using the hand wheel on the front of the machine.



Step 11: Position Components

Position the pipe in the pipe clamps flush with the fully extended retractable pipe stop and clamp into place. Then, retract both the clamp crossbar and the pipe stop before starting the fusion process.



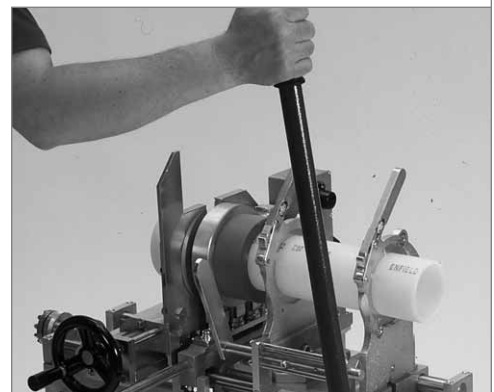
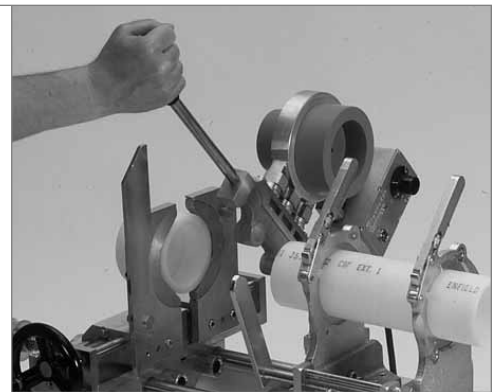
Step 12: Heat Components

Lower the heating mirror into position between the pipe and fitting, swinging the motion lever from right to left until a stop is reached. This will bring pipe and fittings to full engagement.

Select the recommended heating and welding times as shown in Table 13 (page 24) to determine how long to leave the pipe and fitting in the heater bushings.

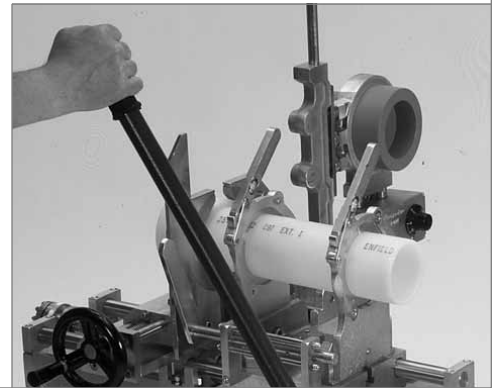
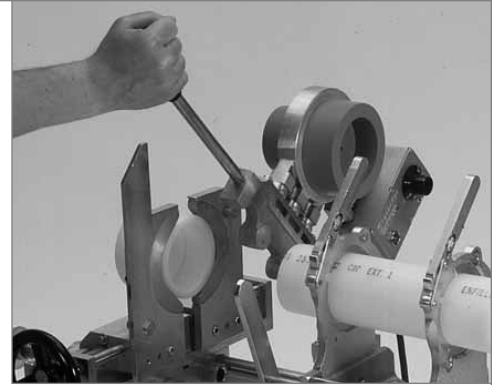
Note: Heating time starts from the moment of full insertion of both pipe and fitting.

Note: If the pipe and fitting do not fit tightly on the heater bushing, heating time should start when the components have swelled to just contact the surface of the heater bushings.



Step 13: Assembly

Once the recommended heating and welding time has elapsed, swing the motion lever back, removing the pipe and fitting from the heater bushings. Quickly raise the mirror to the vertical position; then press the pipe and fitting together again by swinging the motion lever until it bottoms out on the insertion depth stop. Hold the completed joint in position for 10 seconds, then release the clamps and remove the joined pipe and fitting from the machine.



Step 14: Clean Bushings

Clean the heater bushings by wiping them off with a clean, dry cloth after each joint. There should not be large amounts of material left on the heater bushings if the fusion is done properly.

Step 15: Joint Setting

Leave the joint to cool slowly at ambient temperature for the recommended minimums as shown in Table 13 (page 24). Allow for proper cooling before pressurizing and testing the system.

NOTE: Never dip the joint into water or expose it to a forced airstream in order to cool it quickly. Weak joints will result.

JOINING METHODS – THREADING

Characteristics

Threading of Enpure pipe is only recommended for Schedule 80. The wall thickness is diminished at the point of threading and thereby reduces the maximum working pressure by 50%. Because of this, threaded pipe should not be used in high pressure systems nor in areas where a leak might endanger personnel. Threaded joints will not withstand constant or extreme stress and strain and must be supported or hung with this in mind.

NOTE: Using threaded Enpure products at high temperatures should be avoided. Consult IPEX for specific details.

Tools & Equipment

- Power threading machine
- Threading ratchet and pipe vise (if hand pipe stock is used)
- Pipe dies designed for plastic
- Strap wrench
- Teflon* tape (PTFE)
- Cutting and de-burring tool
- Ring gauge (L-1)

* Trademark of the E.I. DuPont Company



Making the Pipe Thread

1. Cutting and De-burring

Enpure pipe should be cut square and smooth for easy and accurate threading. A miter box or similar guide should be used when sawing is done by hand. Burrs should be removed inside and out using a knife or plastic pipe deburring tool.

2. Threading

Threading Schedule 80 Enpure pipe can be easily accomplished using either a standard hand pipe stock or a power operated tool. Cutting dies should be clean and sharp.

Power-threading machines should be fitted with dies having a 5° negative front rake and ground especially for plastic pipe. Self opening die heads, and a slight chamfer to lead the dies will speed the operation; however, dies should not be driven at high speeds or with heavy pressure.

When using a hand held cutter, the pipe should be held in a pipe vise. To prevent crushing or scoring of the pipe by the vise jaws, some type of protective wrap such as canvas, emery paper, rubber, or light metal sleeve should be used.

For hand stocks, the dies should have a negative front rake angle of 5° to 10°. Enpure is readily threaded and caution should be taken not to over-thread. This procedure is best done in a shop or fabricating plant. Thread dimensional specifications can be found in Table 14 - American National Standard Taper Pipe Threads (NPT).

Caution: Threading oils that are compatible with thermoplastics should be used. Failure to do so may result in property damage due to leaks.

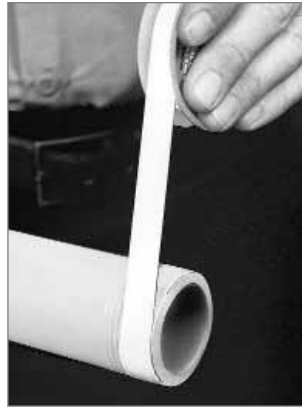
Installation Guidelines

1. Preparing the Threaded Pipe

A ring gauge should be used to check the accuracy of the threads.

Tolerance = \pm 1-1/2 turns

The threads should be cleaned by brushing away cuttings and ribbons. After cleaning, apply thread lubricant such as Teflon® tape (PTFE) or to the threaded portion of the pipe.



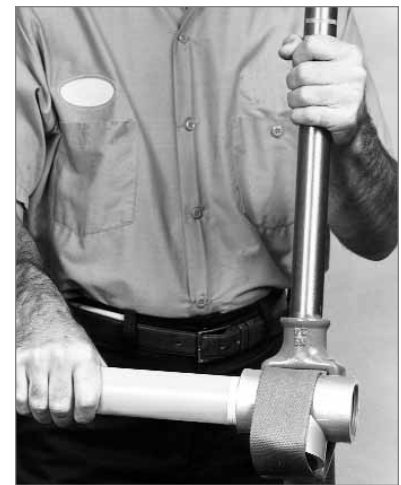
Wrap the tape around the entire length of threads beginning with number two thread from the end. The tape should slightly overlap itself going in the same direction as the threads. This will prevent the tape from unraveling when the fitting is tightened on the pipe. Overlapping in the wrong direction and the use of too much tape can affect tolerances between threads.

This can generate stress in the wall of female fittings resulting in failure during operations.

2. Assembly of Threaded Joints

After applying thread lubricant, screw the threaded fitting onto the pipe. Screwed fittings should be started carefully and hand tightened. Threads must be properly cut and a good quality Teflon® tape must be used. If desired, the joint may be tightened with a strap wrench. In NO INSTANCE should a pipe or chain wrench be used as the jaws of this type of wrench will scar and damage the pipe wall.

Fittings should be threaded together until hand tight with an additional 1/2 to 1 turns more. Avoid stretching or distorting the pipe, fittings or threads by over tightening.



An American National Standard Pipe Threads, General Purpose (inch)

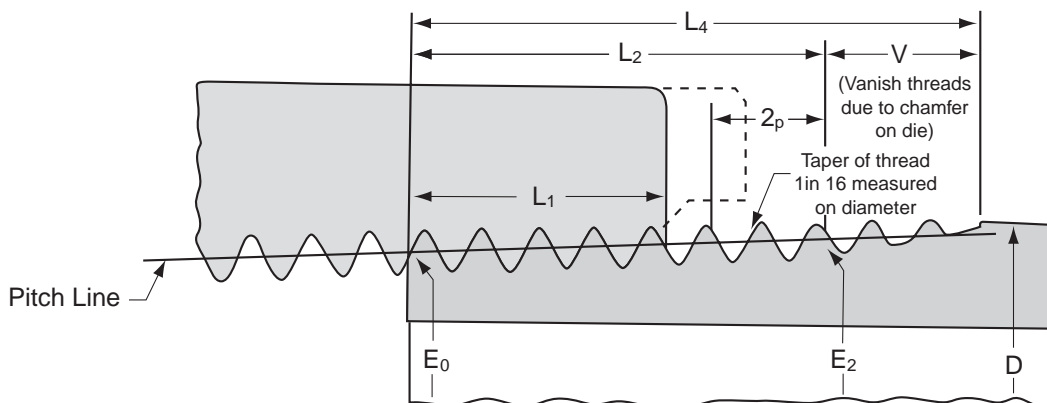


Table 14 - American National Standard Taper Pipe Threads (NPT)¹

Nominal Pipe Size	O.D. of Pipe (D)	Threads per inch (n)	Pitch of Thread (P)	Pitch Diameter at Beginning of External Thread (E_0)	Handtight Engagement Length ² (L_1)		Effective Thread, External Length ³ (L_2)		Vanish Thread (V)		Overall Length External Thread ⁴ (L_4)	Height of Thread (h)
					Inch	Threads	Inch	Threads	Inch	Thread		
1/2	0.840	14	0.07143	0.75843	0.320	4.48	0.5337	7.47	0.2478	3.47	0.7815	0.05714
3/4	1.050	14	0.07143	0.96768	0.339	4.75	0.5457	7.64	0.2478	3.47	0.7935	0.05714
1	1.315	11.5	0.08696	1.21363	0.400	4.60	0.6828	7.85	0.3017	3.47	0.9845	0.06957
1-1/4	1.660	11.5	0.08686	1.55713	0.420	4.83	0.7068	8.13	0.3017	3.47	1.0085	0.06957
1-1/2	1.900	11.5	0.08696	1.79609	0.420	4.83	0.7235	8.32	0.3017	3.47	1.0252	0.06957
2	2.375	11.5	0.08696	2.26902	0.436	5.01	0.7565	8.70	0.3017	3.47	1.0582	0.06957
3	3.500	8	0.12500	3.34062	0.766	6.13	1.2000	9.60	0.4337	3.47	1.6337	0.100000
4	4.500	8	0.12500	4.33438	0.844	6.75	1.3000	10.40	0.4337	3.47	1.7337	0.100000

NOTE:

1. The basic dimensions of the American National Standard Taper Pipe Thread are given in inches to four or five decimal places. While this implies a greater degree of precision than is ordinarily attained, these dimensions are the basis of gage dimensions and are so expressed for the purpose of eliminating errors in computations.
2. Also length of thin ring gage and length from gaging notch to small end of plug gage.
3. Also length of plug gage.
4. Reference dimension

JOINING METHODS – FLANGING

Introduction

Flanging is used extensively for plastic process lines that require periodic dismantling. Thermoplastic flanges in Enpure are available up to 4". Gasket seals between the flange faces should be an elastomeric gasket with a hardness of 50 to 70 durometer A. EPDM gaskets are commonly used. For chemical environments beyond the capabilities of EPDM, more resistant elastomers such as FPM or PTFE envelope gaskets should be used.



Dimensions

IPEX Enpure flanges are the same as metal flanges per ANSI B16.1. The socket dimensions conform to ASTM D 2467 which describes 1/2" through 4".

Maximum pressure for any flanged system is the rating of the pipe or up to 150 psi.

Table 15 – Maximum Pressures for Flanged Systems

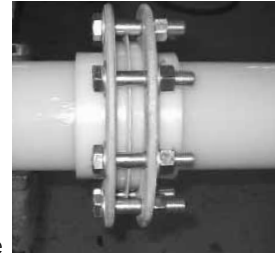
Pipe	Operating Temperature		Maximum Operating Pressure (psi)	
	°F	°C	1/2" to 2"	3" & 4"
Sch 80	73	23	150	115
Sch 40	73	23	120	80

Installation Guidelines

The faces of IPEX flanges have a phonographic-grooved finish providing positive seal on the gasket when the bolts are properly tightened.

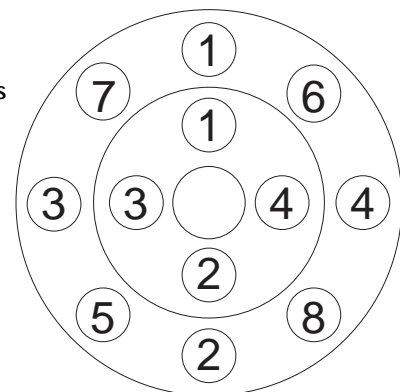
Once a flange is joined to pipe, use the following method to join two flanges together:

1. Make sure all bolt holes of the matching flanges are aligned.
2. Insert all bolts.
3. Make sure the faces of the mating flanges are not separated by excessive distance prior to bolting down the flanges.
4. The bolts on the plastic flanges should be tightened by pulling down the nuts diametrically opposite each other using a torque wrench. Complete tightening should be accomplished in stages using the final torque values in Table 14 – Recommended Torque. Uniform stress across the flange will eliminate leaky gaskets.



The following tightening pattern is suggested for the flange bolts.

Flange Bolt Tightening Patterns



5. If the flange is mated to a rigid and stationary flanged object or a metal flange the plastic flange and fitting or valve must be supported to eliminate potential stressing.



CAUTION

1. Do not over-torque flange bolts.
2. Use the proper bolt tightening sequence.
3. Make sure the system is in proper alignment.
4. Flanges should not be used to draw piping assemblies together.
5. Flat washers must be used under every nut and bolt head.

Table 16 – Recommended Torque

Flange Size (in.)	Recommended Torque (ft. lbs.)*
1/2 – 1-1/2	15
2 – 4	30

* Based on using Enpure flanges, a gasket, and well lubricated hardware, tightened in the proper sequence and applying torque in small increments. For PP-to-metal flange (or other materials), these torque recommendations may vary.

Table 17 – Flange Bolt Set

Pipe Size	No. of Holes	Bolt Diameter	Bolt Length
1/2	4	0.50	1.75
3/4	4	0.50	2.00
1	4	0.50	2.00
1-1/4	4	0.50	2.25
1-1/2	4	0.50	2.50
2	4	0.63	2.75
3	4	0.63	3.00
4	8	0.63	3.25

* Bolt length will vary if metal backing rings are used.

INSTALLATION

Layout

For high purity systems, the piping system should be designed to prevent areas where water can stagnate. Stagnant fluid is undesirable as it can increase the potential for contamination and bacterial growth thereby lowering the purity of the fluid. Designers should minimize dead legs in the system and reduce or eliminate threaded connections wherever possible.

Supports and Restraints

Thrust

Thrust forces can occur at any point in a piping system where the directional or cross-sectional area of the waterway changes or where additional structural loads such as valves are installed. These forces must be reduced by means of anchors, risers or restraining hangers.

The size or need for reinforcements should be based on the design engineer's evaluation of flow velocities and pressure increases due to the fluid's momentum. Note that the thrust created at unrestrained fittings can be considerable (as shown in Table 18) and should be addressed during installation. For more detail regarding estimating and compensating for thrust forces, refer to engineering textbooks.

Note that all valves must be anchored. This includes valves installed in line and those that are operated infrequently.

Table 18 – Thrust at Fittings in lbs. per 100 psi (internal pressure)

Pipe Size (in.)	Blank ends & junctions (psi)	90° Bends (psi)	45° Bends (psi)
1/2	60	85	50
3/4	90	130	70
1	140	400	110
1-1/4	220	320	170
1-1/2	300	420	230
2	450	630	345
3	970	1,360	745
4	1,600	2,240	1,225

General Principles of Support

Adequate support for any piping system is a matter of great importance. In practice, support spacing is a function of pipe size, operating temperatures, the location of heavy valves or fittings, and the mechanical properties of the pipe material.

To ensure satisfactory operation of a thermoplastic piping system, the location and type of hangers should be carefully considered. The principles of design for steel piping systems are generally applicable to thermoplastic piping systems, but with some notable areas where special consideration should be exercised.

1. Concentrated loads (i.e. valves, flanges, etc.) should be supported directly to eliminate high stress concentrations on the pipe. Should this be impractical, the pipe must then be supported immediately adjacent to the load.
2. In systems where large fluctuations in temperature occur, allowance must be made for expansion and contraction of the piping system. Since changes in direction in the system are usually sufficient to allow expansion and contraction, hangers must be placed so movement is not restricted. (See also Expansion-Contraction in the Design section in this manual). Note that in some instances it may be desirable to use a clamp-type hanger to direct thermal expansion or contraction in a specific direction. When using a clamp-type hanger, the hanger should not deform the pipe when it has been tightened. (See Figure 5 Recommended Pipe Hangers)
3. Changes in direction (e.g. 90° elbows) should be supported as close as practical to the fitting to avoid introducing excessive torsional stresses into the system.
4. Hangers should provide as much bearing surface as possible. Sharp supports or sharp edges on supports should not be used with these materials since they will cause mechanical damage if the pipe moves.
5. Valves should be braced against operating torque. Heavy metal valves should be supported so as not to induce additional stress on the thermoplastic piping system.

Tables 19 and 20 give recommended maximum support spacing for Enpure pipe at various temperatures. The data is based on fluids with a specific gravity of 1.0. For heavier fluids, the support spacing from the graphs should be multiplied by the correction factors shown in Table 21.

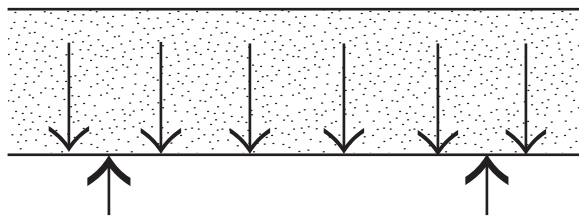
Note that these maximum recommendations should always be referenced against local plumbing and mechanical codes as well as the local authority having jurisdiction.

Calculation of Support Spacing

$$L = \frac{[(SL \times E \times I) / (1.302 \times Wt)]^{0.333}}{12}$$

where:

- L = Length between supports, 'Span Length', ft.
- SL = Sag Limit, the maximum permitted vertical deflection allowed across a span, expressed as a percentage of the span length for 0.2% SL = 0.2
- E = Modulus of elasticity of the pipe material, psi (E = 188550 psi) @ 73°F
- OD = Outside Diameter of the pipe, in
- I = $(\pi / 64) \times (OD^4 - ID^4)$
- Wt = $0.02837 \times (\delta - \text{pipe} \times (OD^2 - ID^2) + \delta - \text{fluid} \times ID^2)$
- δ -pipe = Density of pipe material, g/cc = Specific Gravity x 0.9975
- δ -fluid = Density of the fluid, g/cc
- ID = Inside diameter of the pipe, in



Assume the load is uniformly distributed along the span length

Table 19 – Maximum Allowable Support Spacing for Enpure Schedule 40

Pipe Size (in.)	Support Spacing (ft.)					
	73°F (23°C)	90°F (32°C)	110°F (43°C)	140°F (60°C)	160°F (71°C)	180°F (82°C)
1/2	2.3	2.2	2.1	2.0	1.9	1.9
3/4	2.5	2.4	2.3	2.1	2.1	2.0
1	3.0	2.8	2.7	2.5	2.4	2.4
1-1/4	3.3	3.2	3.0	2.8	2.7	2.6
1-1/2	3.5	3.4	3.2	3.0	2.9	2.8
2	3.9	3.8	3.6	3.4	3.2	3.1
3	5.0	4.8	4.6	4.3	4.1	4.0
4	5.6	5.4	5.2	4.8	4.7	4.5

Note: Based on a maximum sag limit of 0.2% of span length
Always consult with local authority having jurisdiction

Table 20 – Maximum Allowable Support Spacing for Enpure Schedule 80

Pipe Size (in.)	Support Spacing (ft.)					
	73°F (23°C)	90°F (32°C)	110°F (43°C)	140°F (60°C)	160°F (71°C)	180°F (82°C)
1/2	2.4	2.3	2.3	2.1	2.0	2.0
3/4	2.7	2.6	2.5	2.4	2.3	2.2
1	3.1	3.0	2.9	2.7	2.6	2.5
1-1/4	3.5	3.4	3.3	3.0	2.9	2.8
1-1/2	3.8	3.7	3.5	3.3	3.1	3.0
2	4.3	4.1	3.9	3.7	3.5	3.4
3	5.4	5.2	5.0	4.7	4.5	4.3
4	6.2	6.0	5.7	5.3	5.1	5.0

Note: Based on a maximum sag limit of 0.2% of span length
Always consult with local authority having jurisdiction

When the fluid has a specific gravity greater than water (1.0), the hanging distance must be decreased by dividing the recommended support distance by the fluid's specific gravity.

Table 21 – Support Spacing Correction Factors

Specific Gravity	1.0	1.1	1.2	1.4	1.6	2.0	2.5
Correction Factor	1.00	0.98	0.96	0.93	0.90	0.85	0.80

Support Types

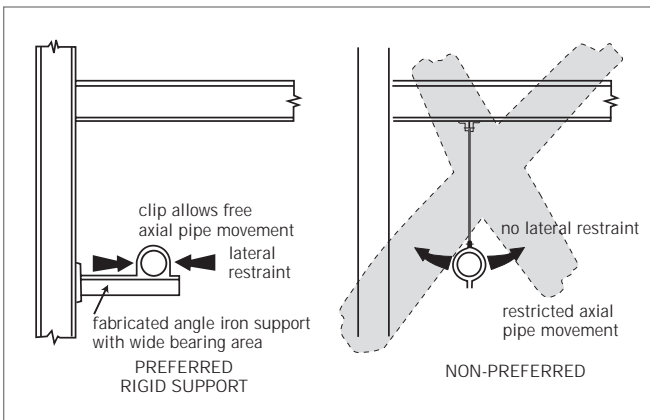
Supports should have the following characteristics:

- **A wide area of contact** – to avoid stress concentrations.
- **Rigid construction** – to adequately support the pipe.
- **Free of sharp burrs or edges** – to avoid chafing or cutting the pipe.
- **Allow free axial pipe movement** – to allow pipe expansion and contraction.
- **Provide lateral restraint** – to avoid pipe snaking.

Rigid Support

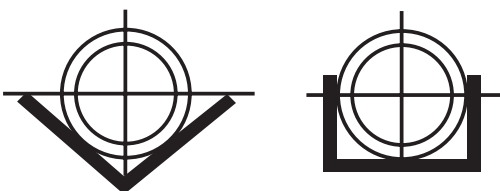
The preferred rigid support, as shown in Figure 4, is comprised of a pipe support and a pipe clip that has a wide bearing area that gives good support to the pipe. While hanger rods can be used to support Enpure, they are not preferred since they offer minimal lateral restraint that could encourage pipe snaking. In situations where it is impractical to install the rigid-type design, such as between widely spaced columns, hanger rods may be used, but they must have loose fitting clips and the rods should be kept short and to a minimum.

Figure 4 – Rigid Pipe Support



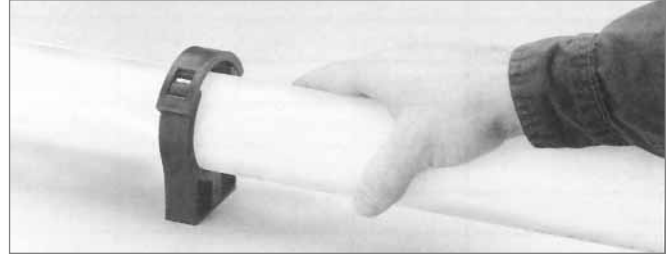
Continuous Support

Continuous support may be advantageous and more economical at elevated temperatures than intermittent supports. Either "V" or "U"-shaped channel supports made from metal, fiberglass or other heat resistant plastic materials have proven to be satisfactory, continuous support types.



Pipe Clips

Any pipe clips that are used in conjunction with Enpure should allow free axial pipe movement while providing lateral restraint.



IPEX's Saddle clips and Cobra clips meet these requirements. Both are manufactured from polypropylene and are quick and easy to install. The added advantage of the Cobra clip is that it is affixed with a single screw or pin. Several Cobra clips can be installed prior to the pipe which is then simply snapped into place, speeding up installation time.



Support of Heavy Equipment

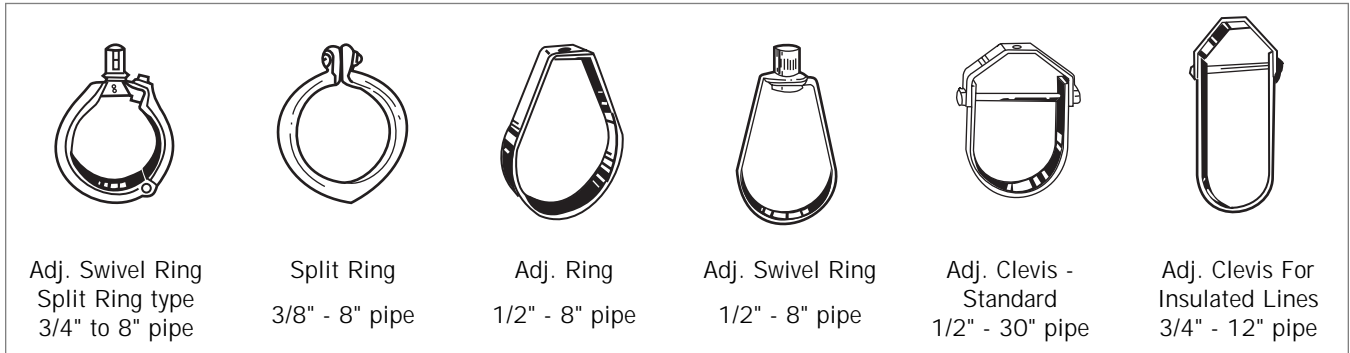
Large valves, filters and other equipment should always be independently supported as well as being anchored to prevent stress and loading of the piping system.

For smaller valves and equipment, two pipe clips situated immediately adjacent to either side of the equipment will provide support and prevent transmission of stress and excess torque to the system.

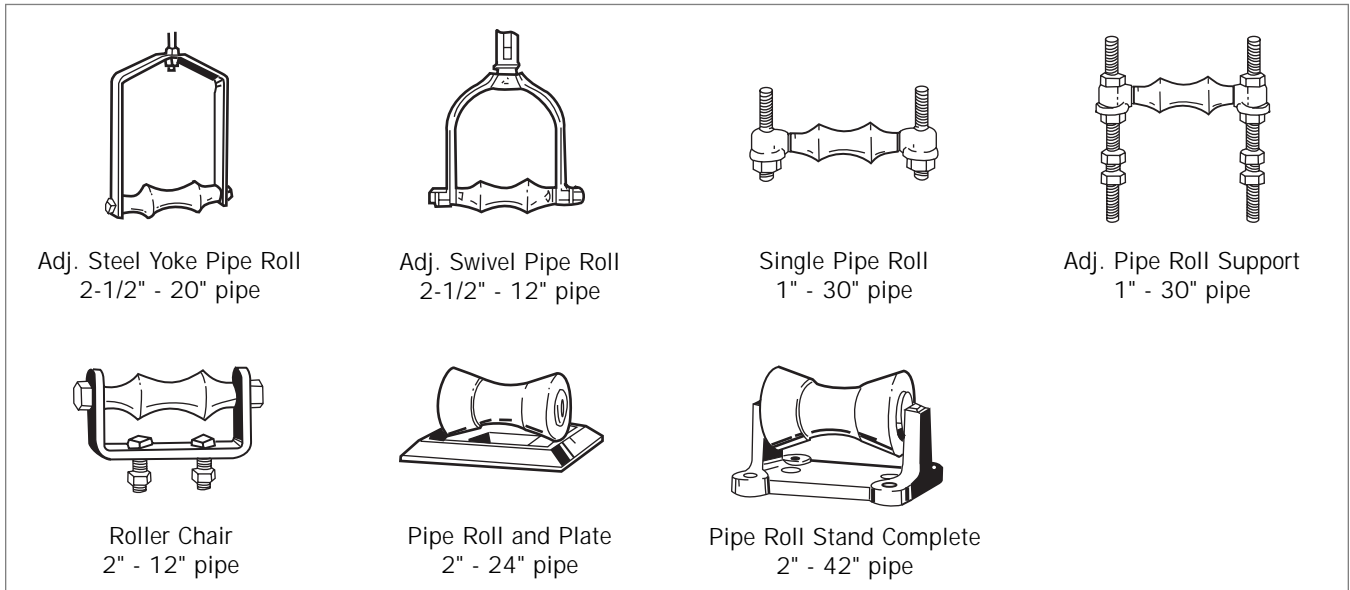


Figure 5 – Recommended Pipe Hangers for Thermoplastic Piping Systems

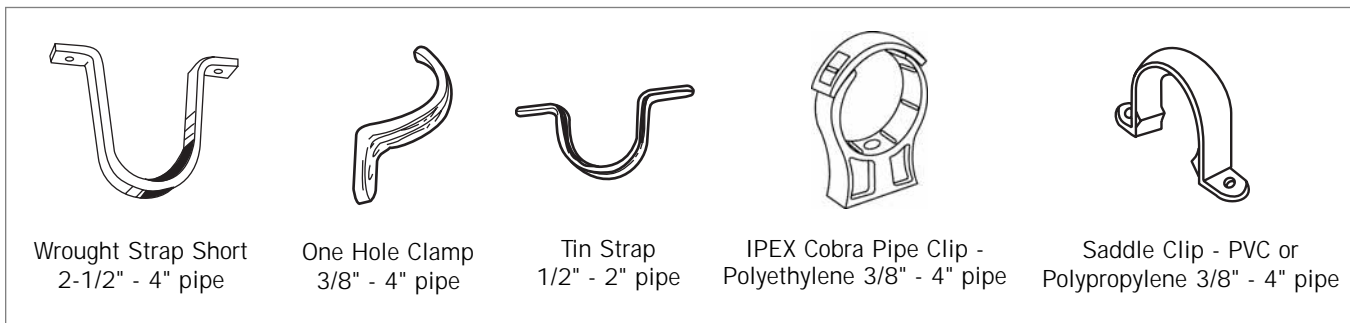
Pipe Rings



Pipe Rolls



Pipe Straps and Hooks



All pipe clips should permit free axial pipe movement at all temperatures and should provide adequate bearing support to the pipe.

Metal clips and supports should be free of sharp edges to prevent damaging the pipe.

INSTALLATION CONSIDERATIONS

Entrapped Air

Air entrapment in pressure pipelines is a much studied and discussed topic. Most designers are concerned about it but may not understand the full implications of the problem or the processes used to reduce the dangers associated with entrapped air. The problem with entrapped air is a complex issue. The behavior of air in a piping system is not easy to analyze, but the effects can be devastating.

Sources of Air in Pipelines

There are many potential sources for air in pipelines and the sources are usually multiple in any given system. The most likely source occurs during filling, either initially or when refilled after drainage. In some systems, air re-enters each time the pumps are shut off as the pipelines drain through open valves or faucets.

Air is often introduced at the point where water enters the system. This is an especially common problem with gravity fed pipelines, but may occur with pumped systems as well.

A less obvious source of air comes from the release of dissolved air in the water, due to changes in temperature and/or pressure. The quantities may be small in this case, but accumulations over time can create problems.

It is also common for air to enter through mechanical air release valves or vacuum breakers when the pressure drops below atmospheric pressure. This can occur during pump shutdown or during negative surges.

Why is Entrapped Air a Problem?

Air in a piping system tends to accumulate at high points during low flow or static conditions. As the flowrate increases, the air can be forced along the pipeline by the moving water and may become lodged at the more extreme high points where it reduces the area available for flow. Thus, these pockets of air cause flow restrictions that reduce the efficiency and performance of the system.

As an air pocket grows, the velocity past that point increases until eventually the air is swept on toward an outlet. While line restrictions are problems, a more serious situation can occur when air is rapidly vented from the system under pressure. Water is about five times more dense than air at 100 psi, so when a pocket of compressed air reaches an outlet, such as a faucet, it escapes very rapidly. As it escapes, water rushes in to replace the void.

When water reaches the opening, the velocity suddenly decreases, since air escapes about five times faster than water at 100 psi. The result is similar to instantaneous valve closure, except that the velocity change can far exceed the normal flow velocity in the pipeline. During tests at Colorado State University, pressure surges **up to 15 times** the operating pressure have been recorded when entrapped air was rapidly vented under pressure. Such pressure surges can easily exceed the strength of the system components and even at lower magnitudes, repeated surges will weaken the system with time.

Ultraviolet Light

UV sterilizers for killing bacteria in de-ionized water are common. Over time, the intense light generated by these sterilizers can stress crack natural Polypropylene components directly connected to the sterilizer.

When UV sterilizers are used, it is recommended that a stainless steel trap be used. Typically 3 foot long spools are used on either side of the UV sterilizer to transition the natural PP components in and out of the sterilizer.

Ozone

Ozone (O₃) is a form of oxygen. In its pure form, it is an unstable blue gas with a pungent odor. Ozone is used as a bactericide in de-ionized water systems in low concentrations of 0.04 to 5 ppm. It presents no problem to thermoplastic piping in aqueous form.

Ozone deteriorates rubber in trace amounts. Because of its increasing use in sterilizing high-purity water systems, the elastomers used for seats and seals become a matter for concern. Commercial mixtures are ordinarily 2% ozone.

Butyl rubber and ethylene propylene rubber (EPDM) have good resistance to ozone, as does fluorine rubber (Viton) and chlorosulfonated polyethylene (Hypalon). Neoprene and Buna-N or Nitrile are severely attacked.

TESTING

REPAIR

Site Pressure Testing

The purpose of an onsite pressure test is to establish that the installed section of line, and in particular all joints and fittings, will withstand the design working pressure, plus a safety margin, without loss of pressure or fluid.

IPEX recommends that a pressure test is conducted after completing the first 20 or 30 joints to ensure proper installation procedures are being followed.

Hydrostatic Test Procedure

1. Fully inspect the installed piping for evidence of mechanical abuse and/or suspect joints.
2. Split the system into convenient test sections not exceeding 1,000 ft.
3. Slowly fill the pipe section with clean water, taking care to evacuate all entrapped air in the process. Do not pressurize at this stage. Water temperature should not exceed 80°F.
4. Leave the section for at least 1 hour to allow equilibrium temperature to be achieved.
5. Check the system for leaks. If clear, check for and remove any remaining air and increase pressure up to 50 psi. Do not pressurize further at this stage.
6. Leave the section pressurized at 50 psi for 10 minutes. If the pressure decays, inspect for leaks. If the pressure remains constant, slowly increase the hydrostatic pressure to 1½ times the nominal working pressure or as specified by the authority having jurisdiction.
7. Leave the section pressurized for a period not exceeding 1 hour. During this time, the pressure should not change.

If there is a significant drop in static pressure or extended times are required to achieve pressure, either joint leakage has occurred or air remains in the line. Inspect for leakage and if none is apparent, reduce the pressure and check for trapped air. This must be removed before further testing.

Joint Repairs

Generally speaking, taking into consideration the cost of materials, time involved and labor costs, the installer is usually better off cutting out the defective joint, replacing it with new materials and taking greater care in the joining process.



WARNING

AIR/GAS



- NEVER use compressed air or gas in PVC/CPVC/PP/PVDF pipe and fittings.
- NEVER test PVC/CPVC/PP/PVDF pipe and fittings with compressed air or gas, or air-over-water boosters.
- ONLY use PVC/CPVC/PP/PVDF pipe for water and approved chemicals.

Use of compressed air or gas in PVC/CPVC/PP/PVDF pipe and fittings can result in explosive failures and cause severe injury or death.

VKD SERIES BALL VALVES

IPEX VKD Series Ball Valves offer a variety of advanced features such as the patented seat stop carrier, a high quality stem and ball support system, and a multifunctional handle with optional lock. The new DUAL BLOCK® system locks the union nuts preventing back-off due to vibration or thermal cycling. Deep grooves, thick o-rings, and cushioned Teflon® seats contribute to strong seals under pressure while an integral mounting features and bracketing combine for simple adaptation for actuation and anchoring. Pressure rated to 150 psi at 73°F (23°C). Sizes 1/2" to 2".

Sample Specification

1.0 Ball Valves - VKD

1.1 Material

- The valve body, stem, ball and unions shall be made of virgin, unpigmented, Type 1 homopolymer Polypropylene according to ASTM D4101.
- The polypropylene shall not contain antioxidants, plasticizers, or other additives that may compromise the purity of the system.

1.2 Seats

- The ball seats shall be made of Teflon® (PTFE).

1.3 Seals

- The o-ring seals shall be made of Viton® (FPM).

- ##### 1.4 All wetted parts of the valves shall comply with standards that are equivalent to NSF Standard 61 for potable water.

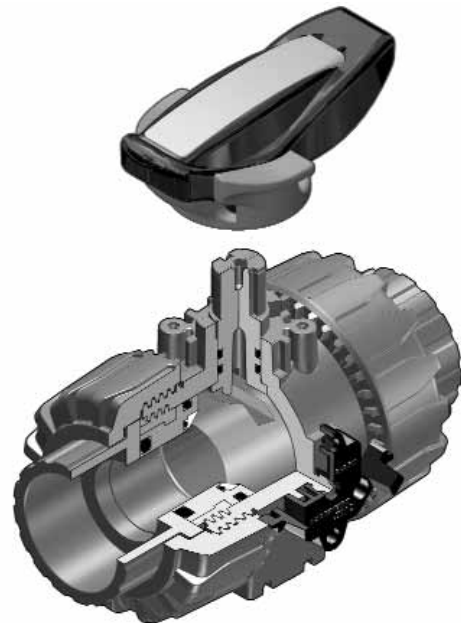
2.0 Connections

2.1 Socket style

- The socket PP end connectors shall conform to IPS dimensions outlined in standards ASTM D-2466 and ASTM D2467.

3.0 Design Features

- The valve shall be double blocking with union ends.
- All sizes 1/2" through 2" shall be full port.
- All sizes shall allow for bi-directional flow.
- The valve body shall be single end entry with a threaded carrier (ball seat support).
- The threaded carrier shall be adjustable with the valve installed.
- The valve body shall have an expansion and contraction compensating groove on the molded end.
- The valve body, union nuts, and carrier shall have deep square style threads for increased strength.
- The ball shall be machined smooth to minimize wear on valve seats.



- All valve seats shall have o-ring backing cushions to compensate for wear and prevent seizure of the ball.
- The stem design shall feature double o-ring seals as well as a safety shear point above the o-rings.
- The handle shall incorporate a removable tool for adjustment of the threaded carrier.
- All valves shall have integrally molded mounting features for actuation.
- All valves shall have integrally molded support bracketing for anchoring.
- The valve shall include the Dual Block® union nut locking mechanism.

3.1 Pressure Tested

- All valves shall have been pressure tested in both the open and closed positions by the manufacturer.

3.2 Pressure Rating

- Valve sizes 1/2" through 2" shall be rated at 150 psi at 73°F (23°C).

3.3 Markings

- All valves shall be marked to indicate size, material designation, and manufacturers name or trade mark.

3.4 Color Coding

- Valves shall not be color-coded and be natural white in appearance.

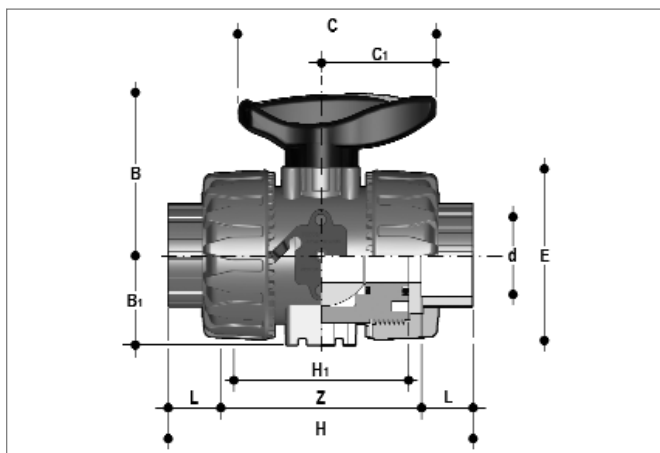
- #### 4.0 All valves shall be Enpure PP by IPEX or approved equal.

VKD SERIES BALL VALVES (CONT'D)

Dimensions

Size (in)	d (in)	L (in)	Z (in)	H (in)	H1 (in)	E (in)
1/2	0.84	0.89	2.83	4.61	2.56	2.13
3/4	1.05	1.00	3.07	5.08	2.76	2.56
1	1.32	1.13	3.33	5.59	3.07	2.87
1-1/4	1.66	1.26	3.86	6.38	3.46	3.39
1-1/2	1.90	1.38	4.02	6.77	3.66	3.86
2	2.38	1.50	4.83	7.83	4.37	4.80

Size (in)	B1 (in)	B (in)	C1 (in)	C (in)	W (lbs)
1/2	1.14	2.13	1.57	2.64	0.32
3/4	1.36	2.56	1.93	3.35	0.48
1	1.54	2.74	1.93	3.35	0.66
1 1/4	1.81	3.25	2.52	4.25	1.06
1 1/2	2.05	3.50	2.52	4.25	1.50
2	2.44	4.25	2.99	5.28	2.57



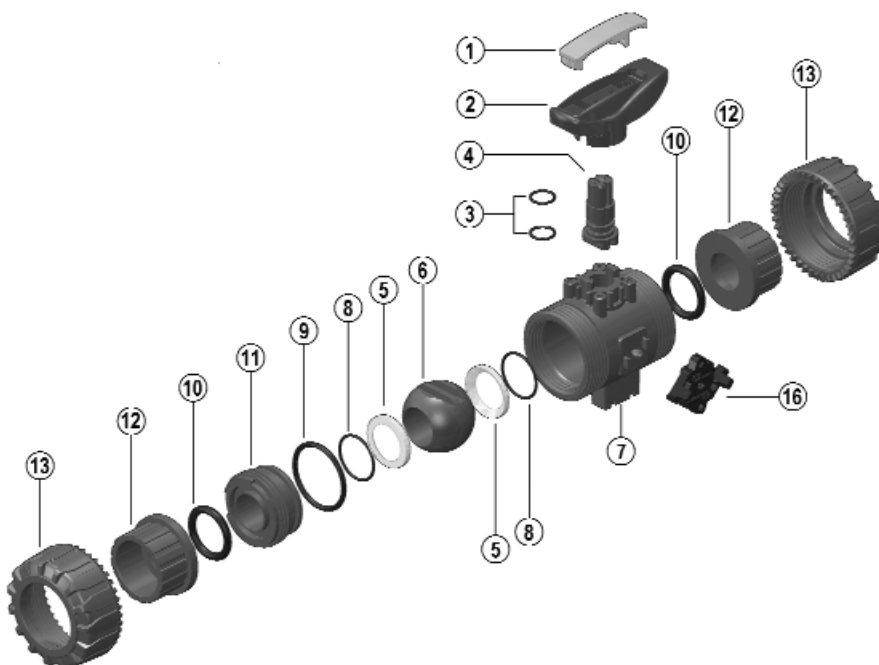
Flow Coefficients

Size (in.)	Cv
1/2	14.0
3/4	27.0
1	53.9
1-1/4	77.0
1-1/2	123
2	238

Flow coefficients (Cv) = flow rate in gallons per minute of water at 68°F (20°C) that will flow through the valve with a 1 psi pressure drop. The Cv values shown in the table are calculated with the valve completely open.

Components

#	Component	Material
1	insert	PVC
2	handle	PVC
3	stem o-ring	VITON®
4	stem	Natural PP
5	ball seat	PTFE
6	ball	Natural PP
7	body	Natural PP
8	ball seat o-ring	VITON®
9	body o-ring	VITON®
10	socket o-ring	VITON®
11	carrier with stop-ring	Natural PP
12	end connector	Natural PP
13	union nut	Natural PP
16	Dual Block®	POM



VM SERIES DIAPHRAGM VALVES

IPEX VM Series Diaphragm Valves are the ideal solution for modulating flow and precise throttling in a variety of applications. The weir-style design prevents the contaminant buildup which could compromise the purity of an Enpure system. The compact modular design allows for installation in any orientation, simple elastomer replacement, and possible conversion to an automated valve without removing the body from the line. Pressure rated to 150 psi at 73°F (23°C). Sizes 1/2" to 2".

Sample Specification

1.0 Diaphragm Valves - VM

1.1 Material

- The valve body shall be made of virgin, unpigmented, Type 1 homopolymer Polypropylene according to ASTM D4101.
- The polypropylene shall not contain antioxidants, plasticizers, or other additives that may compromise the purity of the system.
- The valve bonnet assembly shall be made of high temperature, high strength, glass-filled polypropylene.

1.2 Diaphragm

- The diaphragm shall be made of EPDM.
- or The diaphragm shall be made of Teflon® (PTFE) backed with EPDM.

- ##### 1.3
- All wetted parts of the valves shall comply with standards that are equivalent to NSF Standard 61 for potable water.

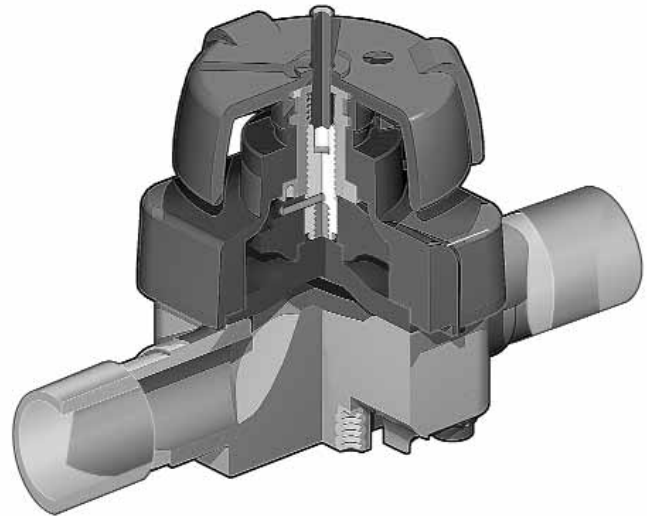
2.0 Connections

2.1 Socket style

- The socket PP end connections shall conform to IPS dimensions outlined in standards ASTM D-2466 and ASTM D2467.

3.0 Design Features

- All valves shall be weir-style for throttling applications..
- All bodies to be used with EPDM diaphragms shall feature raised molded sealing rings (concentric).



- All bodies to be used with PTFE diaphragms shall be machined flat.
- All PTFE diaphragms shall feature a raised molded ring to combine sealing performance and longer life.
- All through bolts shall be made of 304 stainless steel.
- All manual valves shall have a rising position indicator.

3.1 Pressure Rating

- Valve sizes 1/2" through 2" shall be rated at 150 psi at 73°F (23°C).

3.3 Markings

- All valves shall be marked to indicate size, material designation, and manufacturers name or trade mark.

3.4 Color Coding

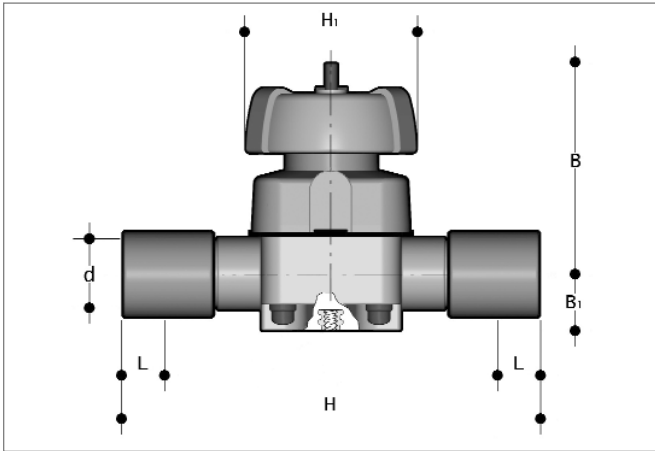
- Valves shall not be color-coded and be natural white in appearance.

- #### 4.0
- All valves shall be Enpure PP by IPEX or approved equal.

VM SERIES DIAPHRAGM VALVES (CONT'D)

Dimensions

Size (in)	d (in)	H (in)	L (in)	B1 (in)	B (in)	H1 (in)	W (lbs)
1/2	0.84	6.22	0.67	1.02	3.74	3.54	1.36
3/4	1.05	7.15	0.74	1.02	3.74	3.54	1.39
1	1.32	7.86	0.90	1.02	3.74	3.54	1.43
1-1/4	1.66	8.65	0.90	1.57	4.96	4.53	2.79
1-1/2	1.90	9.60	0.98	1.57	4.96	4.53	2.90
2	2.38	11.10	1.14	1.57	5.83	5.51	4.63



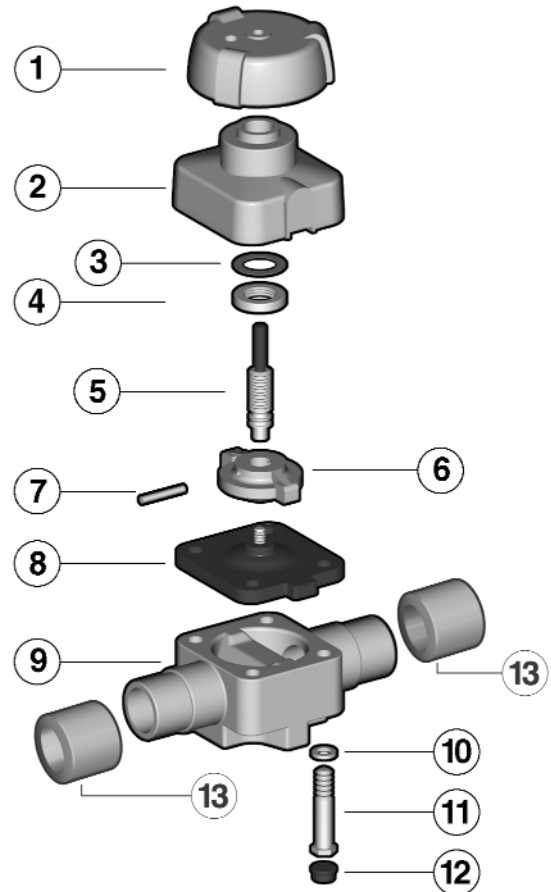
Flow Coefficients

Size (in.)	Cv
1/2	6.51
3/4	9.52
1	12.3
1-1/4	21.0
1-1/2	29.1
2	53.6

Flow coefficients (Cv) = flow rate in gallons per minute of water at 68°F (20°C) that will flow through the valve with a 1 psi pressure drop. The Cv values shown in the table are calculated with the valve completely open.

Components

#	Component	Material
1	handwheel	GFPP
2	bonnet	GFPP
3	compression bearing	POM
4	security ring	Brass
5	indicator - stem	SS
6	compressor	PBT
7	pin	SS
8	diaphragm	EPDM / PTFE
9	valve body	Natural PP
10	washer	Zinc plated steel
11	hex bolt	Zinc plated steel
12	protective cap	PE
13	coupling	Natural PP



SR SERIES BALL CHECK VALVES

IPEX SR Ball Check Valves provide a simple solution for preventing backflow in an Enpure piping system. The single union design allows easy dismantling of the system for in-line maintenance while the blocked support prevents blowout of the internal components and allows for seating adjustment. Full length guide ribs allow for maximum flow and minimum turbulence, preventing ball sticking and chatter. Just a few psi of back pressure is needed for positive shut off in both vertical and horizontal orientations. Pressure rated to 150 psi at 73°F (23°C). Sizes 1/2" to 2".

Sample Specification

1.0 Ball Check Valves - SR

1.1 Material

- The valve body shall be made of virgin, unpigmented, Type 1 homopolymer Polypropylene according to ASTM D4101.
- The polypropylene shall not contain antioxidants, plasticizers, or other additives that may compromise the purity of the system.

1.2 Seals

- The gaskets and o-ring seals shall be made of Viton® (FPM).

- 1.3 All wetted parts of the valves shall comply with standards that are equivalent to NSF Standard 61 for potable water.

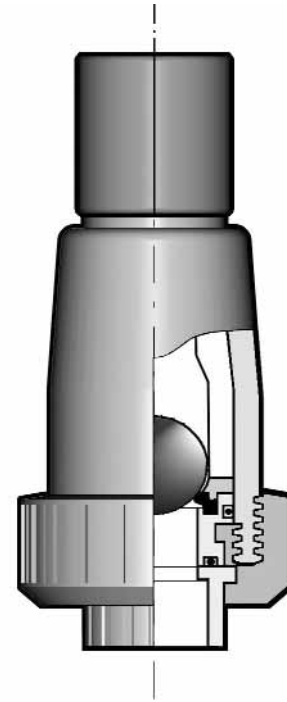
2.0 Connections

2.1 Socket style

- The socket PP end connectors shall conform to IPS dimensions outlined in standards ASTM D-2466 and ASTM D2467.

3.0 Design Features

- The valve shall have a single union design to allow for in-line maintenance.
- The valve body shall be single end entry with a threaded carrier (ball seat support).
- The threaded carrier shall be adjustable with the valve installed.
- The valve body, union nut, and carrier shall have deep square style threads for increased strength.
- The valve body shall have full length guide ribs to allow for maximum flow and minimum turbulence, to prevent ball sticking and chatter.
- The valve shall provide positive shut off in both vertical and horizontal orientations.



3.1 Pressure Rating

- Valve sizes 1/2" through 2" shall be rated at 150 psi at 73°F (23°C).

3.2 Markings

- All valves shall be marked to indicate size, material designation, and manufacturers name or trade mark.

3.3 Color Coding

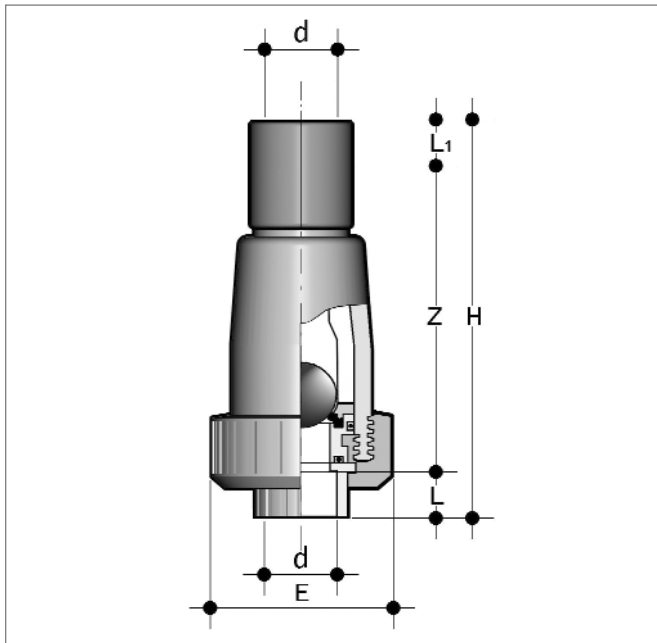
- Valves shall not be color-coded and be natural white in appearance.

- 4.0 All valves shall be Enpure PP by IPEX or approved equal.

SR SERIES BALL CHECK VALVES (CONT'D)

Dimensions

Size (in)	d (in)	L (in)	L1 (in)	Z (in)	H (in)	E (in)	W (lbs)
1/2	0.84	0.63	0.67	3.74	5.04	2.16	0.19
3/4	1.05	0.75	0.74	4.49	5.98	2.60	0.34
1	1.32	0.87	0.90	5.32	7.09	2.91	0.53
1-1/4	1.66	1.02	0.90	6.14	8.06	3.39	0.78
1-1/2	1.90	1.22	0.98	6.66	8.86	3.90	1.09
2	2.38	1.50	1.14	7.80	10.44	4.72	1.87



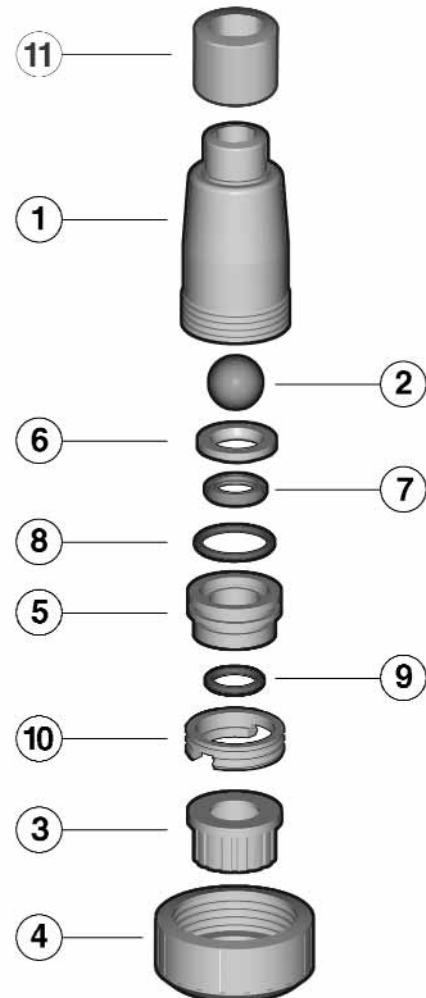
Flow Coefficients

Size (in.)	Cv
1/2	7.70
3/4	14.4
1	16.8
1-1/4	28.7
1-1/2	45.5
2	58.8

Flow coefficients (Cv) = flow rate in gallons per minute of water at 68°F (20°C) that will flow through the valve with a 1 psi pressure drop. The Cv values shown in the table are calculated with the valve completely open.

Components

#	Component	Material
1	body	Natural PP
2	ball	Natural PP
3	end connector	Natural PP
4	union nut	Natural PP
5	support	Natural PP
6	retaining ring	Natural PP
7	ball seat	Viton®
8	body o-ring	Viton®
9	socket o-ring	Viton®
10	seat carrier	Natural PP
11	coupling	Natural PP



RECIRCULATING FAUCET

When there are strict requirements for water purity, it is important to choose the right faucet. Faucet function and faucet materials are critical to this selection. To keep the water bacteria-free and maintain a high level of purity, a recirculating water system is recommended. This type of system will prevent water from stagnating in components by allowing it to continuously circulate through the system. When the water is continuously moving, bacteria cannot establish themselves on interior walls.

These bench mounted metal faucets can be used for demineralized, distilled or deionized water and for other pure water sorts.

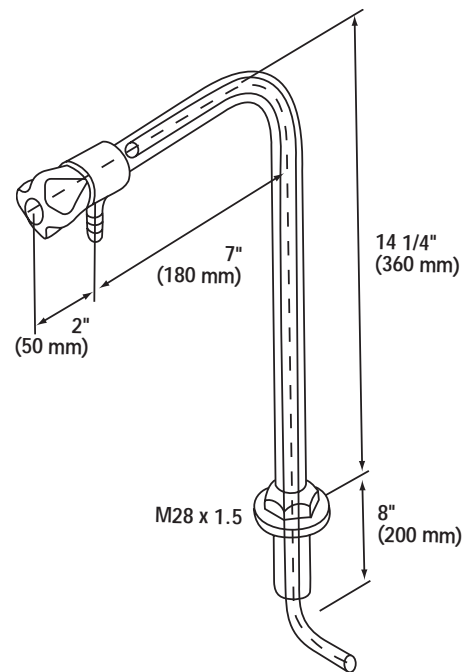
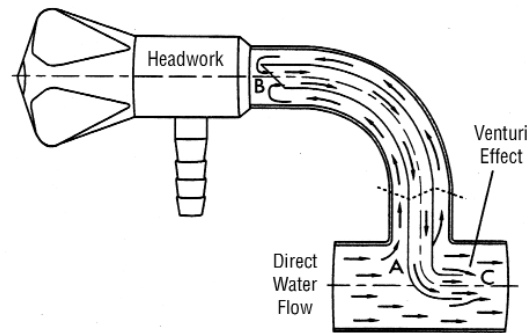
Features and Benefits

- The wet internal components of the Enpure Recirculating Faucet are made of high-purity, natural polypropylene and PVDF, which inhibit material contamination.
- The faucet surfaces have a polyester powdered lacquer which gives our faucets excellent resistance to a wide range of chemicals, UV fading and heat.
- Pressure rating: 150 psi (1,000 kPa).
- Easy installation: faucets are simple to mount and no special tools are needed.
- Pressure testing: each and every fitting is pressure-tested at the factory before shipment.
- Excellent track record: for many years these specially designed, innovative fixtures have been used by professionals in many countries around the globe.

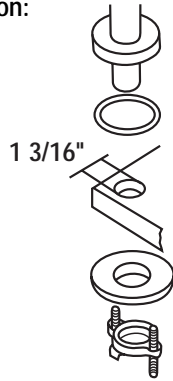
The recirculating effect works as follows irrespective of how the faucet is installed or the direction of main flow:

The faucet fitting consists of an inner and outer pipe. The inner pipe is vented into the main piping.

At point C, the water flow creates a lower pressure at the inner pipe due to a venturi effect. This lower pressure in the inner pipe forces the water from the main flow into the column (at point A), up to the faucet head and into the inner pipe (at point B). The water then flows back down the inner pipe into the main flow creating water recirculation.



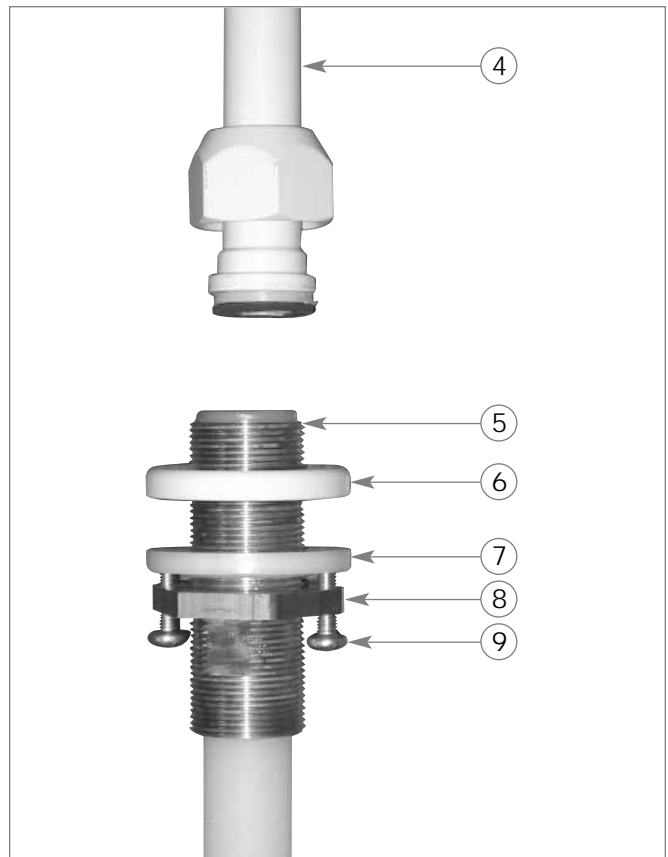
Mounting Information:



Drill 1 3/16" for the inlet

Installation Procedure

1. Drill a 1-3/16" clearance hole in the sink or counter where the faucet is to be located.
2. Thread the top spacer (part # 6, with o-ring) about 1/2" onto the end of the brass nipple (5) with the embedded o-ring. Do not tighten fully as adjustment may be required later. Insert the nipple into the sink or counter.
3. From below, insert the plastic washer (7, grooved end down) on the nipple followed by the threaded brass nut (8).
4. Insert the two screws (9) into the brass nut then tighten both the nut and the screws until the assembly is snug against the sink or counter.
5. Heat and install the pipe spigot (3) into the reducer bushing or tee below the counter as per the standard socket fusion procedure outlined in this manual. The pipe spigot must be inserted into the brass nipple from above.
6. Adjust the brass nipple, spacers, and brass nut until the pipe spigot is pulled up snug against the top of the nipple.
7. Insert the recirculation tube (1) into the upper neck of the faucet (2) then install the assembly into the pipe spigot. Position the faucet as required then tighten the upper nut (4).

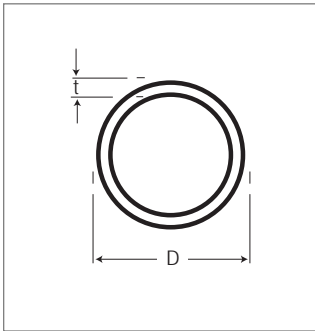


SECTION FIVE: DIMENSIONS

The nominal dimensions of Enpure pipes, fittings and valves are shown below for guidance only and are subject to change. While Enpure is ideally suited for site-run piping, there may be occasions when installers may choose to prefabricate certain portions of the system. In this event, it is essential that IPEX is contacted to ensure the dimensional information given below is still valid.

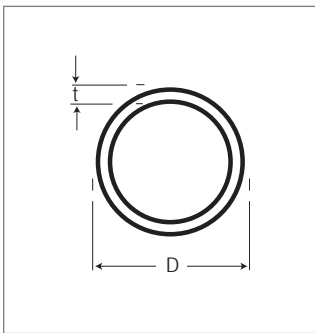
PIPE

Enpure Pipe Schedule 40 (10 ft. lengths)



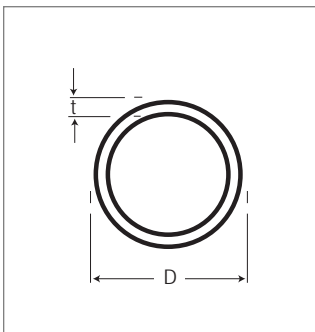
Size (in.)	Significant Part No.	IPEX Part No.	OD (in.)	t min (in.)	t max (in.)
1/2	U1002	546000	0.840	0.109	0.119
3/4	U1003	546001	1.050	0.113	0.123
1	U1004	546002	1.315	0.133	0.143
1-1/4	U1005	546003	1.660	0.145	0.155
1-1/2	U1006	546004	1.900	0.166	0.181
2	U1007	546005	2.375	0.208	0.228
3	U1008	546006	3.500	0.216	0.236
4	U1009	546007	4.500	0.271	0.299

Enpure Pipe Schedule 40 (20 ft. lengths)



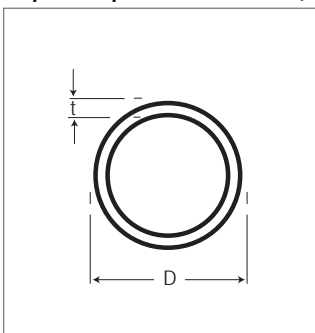
Size (in.)	Significant Part No.	IPEX Part No.	OD (in.)	t min (in.)	t max (in.)
1/2	U1002-20	546020	0.840	0.109	0.119
3/4	U1003-20	546021	1.050	0.113	0.123
1	U1004-20	546022	1.315	0.133	0.143
1-1/4	U1005-20	546023	1.660	0.145	0.155
1-1/2	U1006-20	546024	1.900	0.166	0.181
2	U1007-20	546025	2.375	0.208	0.228
3	U1008-20	546026	3.500	0.216	0.236
4	U1009-20	546027	4.500	0.271	0.299

Enpure Pipe Schedule 80 (10 ft. lengths)



Size (in.)	Significant Part No.	IPEX Part No.	OD (in.)	t min (in.)	t max (in.)
1/2	U1102	546008	0.840	0.147	0.162
3/4	U1103	546009	1.050	0.154	0.169
1	U1104	546010	1.315	0.179	0.194
1-1/4	U1105	546011	1.660	0.191	0.206
1-1/2	U1106	546012	1.900	0.204	0.219
2	U1107	546013	2.375	0.255	0.275
3	U1108	546014	3.500	0.300	0.320
4	U1109	546015	4.500	0.379	0.407

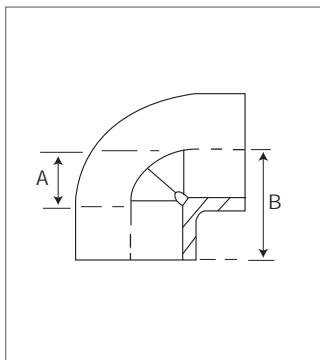
Enpure Pipe Schedule 80 (20 ft. lengths)



Size (in.)	Significant Part No.	IPEX Part No.	OD (in.)	t min (in.)	t max (in.)
1/2	U1102-20	546028	0.840	0.147	0.162
3/4	U1103-20	546029	1.050	0.154	0.169
1	U1104-20	546030	1.315	0.179	0.194
1-1/4	U1105-20	546031	1.660	0.191	0.206
1-1/2	U1106-20	546032	1.900	0.204	0.219
2	U1107-20	546033	2.375	0.255	0.275
3	U1108-20	546034	3.500	0.300	0.320
4	U1109-20	546035	4.500	0.379	0.407

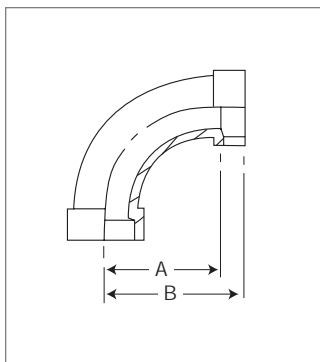
FITTINGS

Empure 90° Elbow (socket)



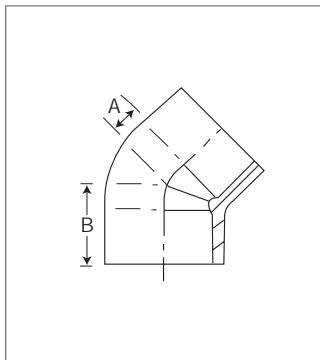
Size (in.)	Significant Part No.	IPEX Part No.	A (in.)	B (in.)
1/2	U1402	537142	0.47	1.14
3/4	U1403	537143	0.55	1.34
1	U1404	537144	0.71	1.61
1-1/4	U1405	537145	0.87	1.77
1-1/2	U1406	537146	1.06	2.05
2	U1407	537147	1.34	2.48
3	U1408	537148	1.89	3.39
4	U1409	537149	2.36	4.13

Empure 90° Bend (socket)



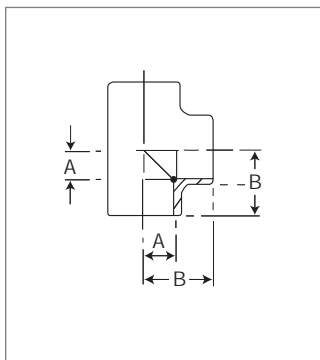
Size (in.)	Significant Part No.	IPEX Part No.	A (in.)	B (in.)
1/2	U2302	537272	2.32	2.87
3/4	U2303	537273	1.73	3.15
1	U2304	537304	2.68	3.35
1-1/4	U2305	537305	3.19	3.98
1-1/2	U2306	537306	2.76	3.66
2	U2307	537307	3.11	4.17
3	U2308	537308	4.60	6.46
4	U2309	537309	4.65	6.85

Empure 45° Elbow (socket)



Size (in.)	Significant Part No.	IPEX Part No.	A (in.)	B (in.)
1/2	U1502	537152	0.20	0.87
3/4	U1503	537153	0.24	1.02
1	U1504	537154	0.28	1.18
1-1/4	U1505	537155	0.39	1.30
1-1/2	U1506	537156	0.51	1.50
2	U1507	537157	0.59	1.73
3	U1508	537158	0.91	2.40
4	U1509	537159	1.02	2.80

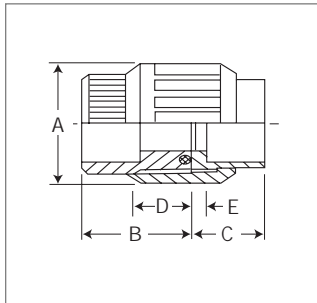
Empure Tee (socket)



Size (in.)	Significant Part No.	IPEX Part No.	A (in.)	B (in.)
1/2	U1602	537162	0.47	1.14
3/4	U1603	537163	0.55	1.34
1	U1604	537164	0.74	1.61
1-1/4	U1605	537165	0.87	1.77
1-1/2	U1606	537166	1.06	2.05
2	U1607	537167	1.34	2.48
3	U1608	537168	1.89	3.39
4	U1609	537169	2.36	4.13

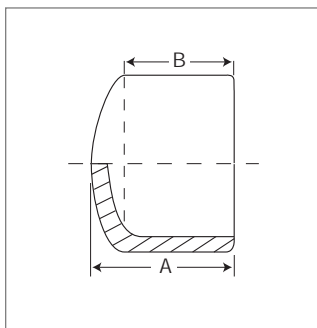
FITTINGS (CONT'D)

Enpure Union (socket, EPDM o-ring standard – FPM available)



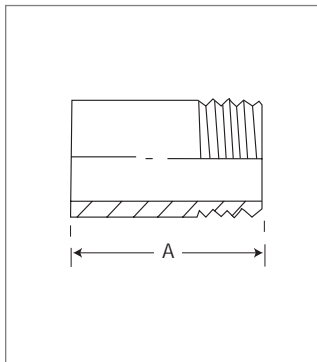
Size (in.)	Significant Part No.	IPEX Part No.	A (in.)	B (in.)	C (in.)	D (in.)	E (in.)
1/2	U1702	537172	1.81	1.42	0.75	0.75	0.08
3/4	U1703	537173	2.09	1.46	0.87	0.67	0.08
1	U1704	537174	2.44	1.50	0.94	0.59	0.04
1-1/4	U1705	537175	2.91	1.61	1.02	0.71	0.12
1-1/2	U1706	537176	4.21	1.81	1.10	0.83	0.12
2	U1707	537177	4.17	2.01	1.26	10.87	0.12

Enpure End Cap (socket)



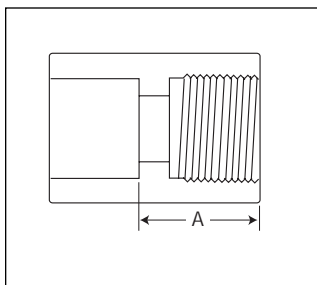
Size (in.)	Significant Part No.	IPEX Part No.	A (in.)	B (in.)
1/2	U1802	537182	1.10	0.67
3/4	U1803	537183	1.18	0.75
1	U1804	537184	1.34	0.91
1-1/4	U1805	537185	1.42	0.91
1-1/2	U1806	537186	1.57	0.98
2	U1807	537187	1.81	1.14
3	U1808	537188	2.40	1.50

Enpure Nipple (spigot x MPT)



Size (in.)	Significant Part No.	IPEX Part No.	A (in.)
1/2	U2402	537322	6.00
3/4	U2403	537323	6.00
1	U2404	537324	6.00
1-1/4	U2405	537325	6.00
1-1/2	U2406	537326	6.00
2	U2407	537327	6.00
3	U2408	537328	6.00
4	U2409	537329	6.00

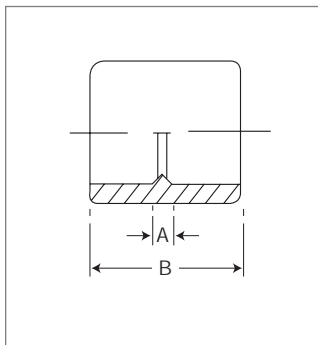
Enpure Female Adapter (socket x FPT)



Size (in.)	Significant Part No.	IPEX Part No.	A (in.)
1/2 x 1/4	U2720	537362	1.25
1/2 x 3/8	U2721	537370	1.25
1/2 x 1/2	U2702	537371	1.13
3/4 x 3/4	U2703	537363	1.22
1 x 1	U2704	537364	1.34
1-1/4 x 1-1/4	U2705	537365	1.50

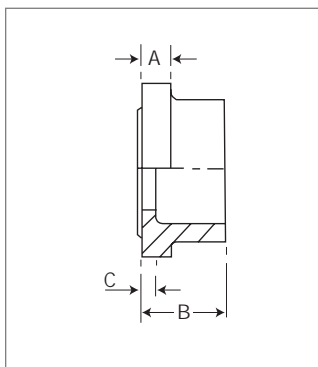
FITTINGS (CONT'D)

Enpure Coupling (socket)



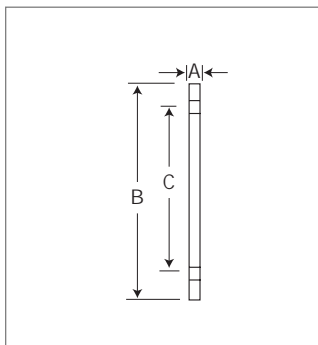
Size (in.)	Significant Part No.	IPEX Part No.	A (in.)	B (in.)
1/2	U1202	537122	0.16	1.50
3/4	U1203	537123	0.16	1.65
1	U1204	537124	0.16	1.97
1-1/4	U1205	537125	0.12	1.93
1-1/2	U1206	537126	0.12	2.09
2	U1207	537127	0.12	2.40
3	U1208	537128	0.20	3.19
4	U1209	537129	0.24	3.78

Enpure Stub Flange (socket, serrated face, ASA 150)



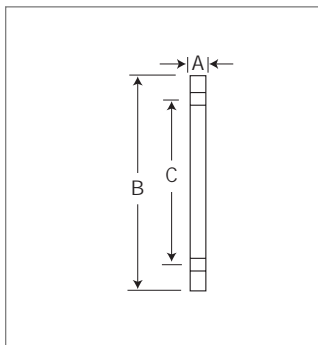
Size (in.)	Significant Part No.	IPEX Part No.	A (in.)	B (in.)	C (in.)	D (in.)	E (in.)
1/2	U1902	537192	1.34	1.06	0.24	0.75	0.08
3/4	U1903	537193	1.61	1.30	0.28	0.87	0.08
1	U1904	537194	1.97	1.61	0.28	0.94	0.04
1-1/4	U1905	537195	2.40	1.97	0.31	1.02	0.12
1-1/2	U1906	537196	2.87	2.40	0.31	1.10	0.12
2	U1907	537197	3.54	2.99	0.35	1.26	0.12
3	U1908	537198	4.92	4.25	0.43	1.69	0.20
4	U1909	537199	5.91	5.16	0.47	1.97	0.20

Enpure Backing Ring (galvanized steel, ASA 150)



Size (in.)	Significant Part No.	IPEX Part No.	A (in.)	B (in.)	C (in.)
1/2	U2112	537222	0.24	3.50	2.36
3/4	U2113	537223	0.24	3.86	2.76
1	U2114	537224	0.24	4.25	3.11
1-1/4	U2115	537225	0.24	4.61	3.50
1-1/2	U2116	537226	0.24	5.00	3.86
2	U2117	537227	0.31	5.98	4.76
3	U2118	537228	0.31	7.48	5.98
4	U2119	537229	0.31	9.02	7.48

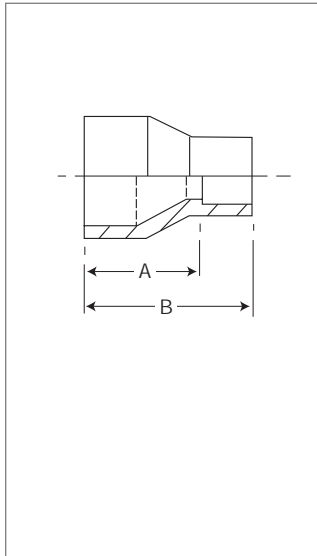
Enpure Blind Flange (ASA 150)



Size (in.)	Significant Part No.	IPEX Part No.	A (in.)	B (in.)	C (in.)
1/2	U2102	537212	0.50	3.50	2.36
3/4	U2103	537213	0.50	3.86	2.76
1	U2104	537214	0.50	4.25	3.11
1-1/4	U2105	537215	0.75	4.61	3.50
1-1/2	U2106	537216	0.75	5.00	3.86
2	U2107	537217	0.75	5.98	4.76
3	U2108	537218	0.75	7.48	5.98
4	U2109	537219	1.00	9.02	7.48

FITTINGS (CONT'D)

Enpure Reducer Bushing (spigot x socket)

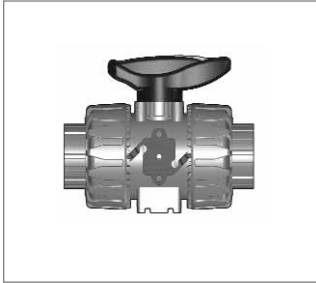


Size (in.)	Significant Part No.	IPEX Part No.	A (in.)	B (in.)
3/4 x 1/2	U2232	537241	0.91	1.50
1 x 1/2	U2242	537242	1.10	1.81
1 x 3/4	U2243	537243	1.10	1.81
1 1/4 x 1	U2254	537244	1.10	1.89
1 1/2 x 1	U2264	537245	1.30	2.24
1-1/2 x 1-1/4	U2265	537246	1.10	2.01
2 x 1	U2274	537247	1.38	2.24
2 x 1-1/4	U2275	537248	1.54	2.52
2 x 1-1/2	U2276	537249	1.26	2.20
3 x 1-1/2	U2286	537250	2.60	3.58
3 x 2	U2287	537251	2.05	3.19
4 x 2	U2297	537252	1.97	3.19
4 x 3	U2298	537253	1.57	3.39

VALVES

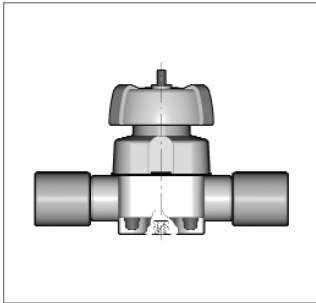
Please refer to Section Four: Valves for dimensions.

VKD Series Ball Valve (True Union socket, Viton® seals, PTFE, seats)



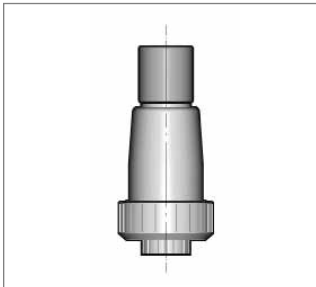
Size (in.)	Significant Part No.	IPEX Part No.
1/2	U3112	537031
3/4	U3113	537032
1	U3114	537033
1-1/4	U3115	537034
1-1/2	U3116	537035
2	U3117	537036

VM Series Diaphragm Valve (Socket, Viton® seals, PTFE or EPDM diaphragm)



Size (in.)	Significant Part No. (PTFE)	IPEX Part No. (PTFE)	Significant Part No (EPDM)	IPEX Part No. (EPDM)
1/2	U3502	537451	U3602	537469
3/4	U3503	537453	U3603	537470
1	U3504	537455	U3604	537471
1-1/4	U3505	537456	U3605	537472
1-1/2	U3506	537457	U3606	537473
2	U3507	537458	U3607	537474

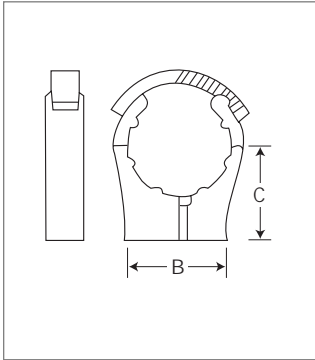
SR Series Ball Check Valve (Single Union socket, Viton® seals & seats)



Size (in.)	Significant Part No.	IPEX Part No.
1/2	U3702	537784
3/4	U3703	537785
1	U3104	537786
1-1/4	U3705	537787
1-1/2	U3706	537788
2	U3707	537789

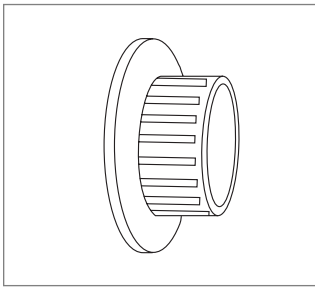
ACCESSORIES

Enpure Cobra Clip



Size (in.)	Significant Part No.	IPEX Part No.	B (in.)	C (in.)
1/2	U2502	437341	1.38	1.18
3/4	U2503	437342	1.38	1.38
1	U2504	437343	1.57	1.57
1-1/4	U2505	437344	1.77	1.77
1-1/2	U2506	437345	1.97	1.97
2	U2507	437346	2.36	2.36
3	U2508	437347	3.15	3.54
4	U2509	437348	3.54	3.77

Enpure End Connector for VKD True Union Ball Valve



Size (in.)	Significant Part No.	IPEX Part No.
1/2	U3102	537014
3/4	U3103	537015
1	U3104	537016
1-1/4	U3105	537017
1-1/2	U3106	537018
2	U3107	537019

This page intentionally
left blank

SECTION SIX: SPECIFICATIONS

ENPURE PP HIGH PURITY INDUSTRIAL PIPING SYSTEMS

Scope

All high-purity water piping as shown on drawings shall be socket-fused, virgin natural polypropylene (containing no regrind material) as manufactured by IPEX. The complete system of piping, valves, fittings, faucets, pipe supports and fusion equipment shall be supplied and warranted by a single manufacturer.

Dimensions

Physical dimensions of Enpure PP pipe and fittings shall meet or exceed Schedule 40 and Schedule 80 requirements.

Piping

Piping shall be manufactured in 10' or 20' (3 m or 6.1 m) lengths to Schedule 40 and Schedule 80 dimensions from virgin, unpigmented, Type 2 high-impact copolymer polypropylene conforming to ASTM D 4101, using no antioxidants or plasticizers. Piping shall be capped at each end and boxed for protection and cleanliness at the point of manufacturing.

Fittings

Fittings shall be manufactured from virgin, unpigmented, Type 2 high-impact copolymer polypropylene conforming to ASTM D 4101, using no antioxidants or plasticizers. Fittings shall be designed for socket fusion utilizing IPEX socket fusion tools and shall have a working design pressure of 150 psi at 73°F (1,000 kPa @ 23°C). All fittings shall be packaged in polybags at the point of manufacturing to preserve fitting cleanliness.

Valves

All valves shall be manufactured from virgin, unpigmented type 1 Homopolymer polypropylene conforming to ASTM D 4101, using no antioxidants or plasticizers that could compromise water quality. Valves shall be designed for socket fusion utilizing IPEX socket fusion tools and shall have a working design pressure of 150 psi @ 73°F (1,000 kPa @ 23°C).

- All ball valves shall be double-blocking type with o-ring cushions under the PTFE seats, in-line micro adjustment capability and incorporate a spanner wrench in the handle.
- All diaphragm valves shall be weir-style featuring smooth (non-drilled) GRF bonnets with integrated fasteners (for cleanliness) and rising position indicator.
- All valves with EPDM diaphragms shall feature concentric ridges on valve body and smooth diaphragms.

- All valves with PTFE diaphragm shall feature machined (smooth) bodies and rigid PTFE diaphragms for positive seal and longer cycle life.
- All ball check valves shall be single union design with micro adjustable locking seat carrier.

Faucets

All metal faucets shall be polyester powder lacquer coated and have non-pigmented polypropylene wetted parts. Faucets shall be recirculating- style to ensure the elimination of static water pockets and shall be rated at 150 psi @ 73°F (1,000 kPa @ 23°C). All faucets shall be fully compatible with all other natural polypropylene piping components in terms of dimensions, quality and purity.

Supports

All piping supports shall incorporate IPEX Cobra clips manufactured from U.V. stabilized polypropylene and designed to allow free axial pipe movement during expansion and contraction of a pipe system. Support spacings shall be to the manufacturer's recommendations for the design temperature of the system.

Installation

Installation shall be in accordance with the contract drawings, the manufacturer's recommendations and the local building codes. The entire system shall be installed stress-free and in proper alignment, with due allowance for expansion and contraction.

Testing

The water-testing requirements on any complete piping system vary dramatically depending on the operating pressure, temperature, installation conditions, jointing method and the proposed service medium. If the testing is not determined by the engineer or governed by regulatory code, the manufacturer should be contacted.

Air or compressed gas shall never be used for pressure testing rigid thermoplastic piping systems.

ENPURE PIPE DIMENSIONS, WEIGHTS & PRESSURE RATINGS

Schedule	Nominal Pipe Size (in.)	Max. Working Pressure @ 73 °F (psi)	Outside Diameter (in.)	Avg. Wall Thickness (in.)	Average Inside Diameter (in.)	Weight of Pipe (lbs./ft)
Sch 40	1/2	120	0.840	0.114	0.602	0.106
Sch 80		150	0.840	0.154	0.526	0.135
Sch 40	3/4	120	1.050	0.118	0.804	0.140
Sch 80		150	1.050	0.161	0.722	0.183
Sch 40	1	120	1.315	0.138	1.029	0.206
Sch 80		150	1.315	0.186	0.936	0.267
Sch 40	1-1/4	120	1.660	0.147	1.360	0.286
Sch 80		150	1.660	0.198	1.255	0.367
Sch 40	1-1/2	120	1.900	0.152	1.590	0.341
Sch 80		150	1.900	0.207	1.476	0.444
Sch 40	2	120	2.375	0.164	2.047	0.469
Sch 80		150	2.375	0.228	1.913	0.622
Sch 40	3	80	3.500	0.226	3.042	0.942
Sch 80		115	3.500	0.310	2.864	1.245
Sch 40	4	80	4.500	0.251	3.998	1.372
Sch 80		115	4.500	0.351	3.786	1.845

SALES AND CUSTOMER SERVICE

Canadian Customers call
Toll free: (866) 473-9462

U.S. Customers call
Toll free: (800) 463-9572

www.ipexinc.com

About IPEX

IPEX is a leading supplier of thermoplastic piping systems. We provide our customers with one of the world's largest and most comprehensive product lines. All IPEX products are backed by over 50 years of experience. With state-of-the-art manufacturing facilities and distribution centers across North America, the IPEX name is synonymous with quality and performance.

Our products and systems have been designed for a broad range of customers and markets. Contact us for information on:

- PVC, CPVC, PP, ABS, PEX, FR-PVDF and PE pipe and fittings (1/4" to 48")
- Industrial process piping systems
- Double containment systems
- Acid waste systems
- High purity systems
- Industrial, plumbing and electrical cements
- Municipal pressure and gravity piping systems
- PE Electrofusion systems for gas and water
- Plumbing and mechanical pipe systems
- Electrical systems
- Telecommunication systems
- Irrigation systems
- Radiant heating systems

WARRANTY: All of the Company's Products are guaranteed against defects resulting from faulty workmanship or materials. The Company will replace, free of charge, including shipping charges for the replacement Products, any Products which are found to be defective in workmanship or material, provided that the following conditions are met:

- a) the Company is promptly notified in writing of such defect immediately upon discovery of same, and the defective Product is promptly returned to the Company;
- b) the defect is not due, without limitation, to faulty installation, misalignment of Products, vibration, ordinary wear and tear, corrosion, erosion, U.V. degradation, incompatible lubricants, pastes and thread sealants, unusual pressure surges or pulsation, water hammer, temperature shocking, or fouling; and
- c) the Products have not been altered or modified after leaving the Company's premises.

The warranty period can be specifically limited for certain Products as stated in writing in the Company's literature.

The Company will not allow claims for labor, materials and/or other expenses required to replace the defective Product, or to repair any damage resulting from the use thereof. The Company disclaims any responsibility for the Purchaser's calculations, product drawings or engineering design specifications. The Company's liability is limited to the purchase price applicable to the product.

It is agreed and understood that the Company's liability in respect to the sale is strictly limited to the replacement of Products as hereinbefore specified and that the Company shall not, in any event, be liable for any damages whether for the loss of use or business interruption or any other claim for incidental, consequential, special or punitive damages. There is no warranty, condition or representation of any nature whatsoever, expressed or implied, by statute or otherwise, except as herein contained, and the Company disclaims any implied warranties of merchantability and/or fitness of its Products for a special purpose.

This literature is published in good faith and is believed to be reliable. However, IPEX does not represent and/or warrant in any manner the information and suggestions contained in this brochure. Data presented is the result of laboratory tests and field experience.

IPEX maintains a policy of ongoing product improvement. This may result in modification of features and/or specifications without notice.



IPEX

MNINEPIPO70603 © 2007 IPEX IND0034UC